

Power transformer and inductor design

***MAGNETICS
TECHNOLOGY
CENTER***

MAGNETICS
DIV. OF SPANG INDUSTRIES INC.
5043 GRAVES AVENUE
SAN JOSE, CALIFORNIA 95129
Phone 408-253-0591 TWX 910-338-0046

MAGNETICS

———— Acknowledgement ————

This paper was provided through the courtesy of the Jet Propulsion Laboratory, California Institute of Technology. The work described was performed by the Spacecraft Power Section of the Guidance and Control Division, under NASA contract NAS 7-100.

Magnetics gratefully acknowledges the contribution of this paper by the author

Colonel Wm. T. McLyman

member of the Guidance and Control Division technical staff.

———— Author's Preface ————

The author wishes to express his thanks to Dr. G.W. Wester and Mr. T. Koerner of JPL, and Mr. R. G. Noah of Magnetics, for support in gathering data, and for their technical aid.

Contents

Tables

Section	Page
List of Symbols	2
1. Introduction – Metric System	2
2. Conversion Data for Wire Sizes from #10 to #44	3
3. Temperature Correction Factors	4
4. Toroidal Fill Factors	4
5. Core Size Selection	6
6. Toroid Powder Core Selection with DC Current	8
7. Calculation of Outside Diameter of Wound Toroid	9
8. Magnetic and Dimensional Specifications for 13 Commonly Used Molypermalloy Cores	10
9. Core Loss for Molypermalloy Powder Cores	17
10. Powder Core (Permeability vs. DC Bias)	17
11. Lamination, C Core, and Bobbin Magnetic and Dimensional Specifications	18
A. Definitions for Tables 16 through 41	18
B. Nomographs for 11 Laminations and 15 C Core Sizes	18
12. Temperature Rise vs. Surface Area Dissipation due to Power Loss, Figure 51	31
13. Maximum Permissible Current Density for 50°C Rise, Figures 52, 53 and 54	32
14. Permeability and Air Gap	33
15. Engineering Aids	34
References	37

1. Conversion Factors	2
2. Wire Table	3
3-15 Magnetic and dimensional specifications for molypermalloy powder cores	10
16-26 Magnetic and dimensional specifications for EE and EI laminations	18
27-41 Magnetic and dimensional specifications for C Cores	24
42. A.I.E.E. Preferred Tape Wound Toroidal Cores	37

Figures

	Page
1. Resistance Correction Factor (ζ , Zeta) for wire temperature between -50 and +100°C	4
2. Fill Factor 0.5	5
3. Fill Factor 0.6	5
4. Fill Factor 0.7	5
5. $W_a A_c$ versus Output Power	7
6. Transformer Weight vs. Output Power	7
7. $W_a A_c$ versus $LI^2/2$	9
8. Inductor Weight vs. $LI^2/2$	9
9. Calculation of Outside Diameter of Wound Toroid	9
10-22 Core wire size nomographs: Inductance vs. resistance	10
23. Core Loss vs. Frequency at 0.05T, 0.1T, and 0.5T	17
24. Permeability vs. DC Bias	17
25-35 Lamination wire size nomographs	18
36-50 C Core wire size nomographs	24
51. Temperature Rise vs. Surface Dissipation	31
52. Current Density vs. Surface Area for a 50°C Rise (Laminations)	32
53. Current Density vs. Surface Area for a 50°C Rise (Toroids)	32
54. Current Density vs. Surface Area for a 50°C Rise (C Cores)	32
55. Lamination A_t	32
56. Toroid A_t	32
57. C Core A_t	32
58. Hysteresis Loop	33
59-66 Hysteresis loops of lamination stacks (1 X 1 interleave thru butt stack)	33
67. Nomograph for Inductance, Capacitance, and Reactance	35
68. Computation of Mean Turn Length	36
69. Silicon, Cobalt, and Nickel-Iron Core Loss Curves	36

List of Symbols

AWG	American wire gauge
cir-mil	area of a circle whose diameter = 0.001 inches
ζ	resistance correction factor for temperature
K_1	conductor area cm^2 / wire area cm^2
K_2	wound area cm^2 / usable window area cm^2
K_3	usable window area cm^2 / window area cm^2
K	window utilization factor
Aw	wire area
Ac	iron area gross
ℓ_m	magnetic path length
MLT	mean length turn
A_t	surface area of a transformer
μ	permeability
W_c	copper loss
W_I	iron loss
W_T	total loss
T	tesla 1 tesla = 1×10^{-4} gauss
R	resistance
I	current (RMS)
E	voltage (RMS)
B_m	operating flux density teslas
f	frequency Hz
W_a	window area
J	current density
P_o	output power
P_i	input power
P_T	total power
η	efficiency
L	inductance
ϕ	flux webers
μ_r	relative permeability
μ_o	absolute permeability ($4\pi \times 10^{-7}$)
H	magnetizing force amp turns/cm 1 amp turn/cm = 0.79 oersted
m	meter

**Table 1. Conversion Factors
To Convert:**

Area		Multiply By
Circular Mils to In.^2		7.854×10^{-7}
Circular Mils to Sq. Mils		7.854×10^{-1}
Circular Mils to Mm.^2		5.066×10^{-4}
Cm.^2 to In.^2		1.55×10^{-1}
Sq. Feet to Sq. Meters		9.29×10^{-2}
In.^2 to Circular Mils		1.273×10^6
In.^2 to Cm.^2		6.4516
In.^2 to Mm.^2		6.4516×10^2
In.^2 to Sq. Mils		1.000×10^6
Sq. Meters to Sq. Feet		1.0764×10^1
Mm.^2 to In.^2		1.55×10^{-3}
Mm.^2 to Circular Mils		1.973×10^3
Sq. Mils to Circular Mils		1.2732
Sq. Mils to In.^2		1.00×10^{-6}
Length		Multiply By
Centimeters to Inches		3.937×10^{-1}
Centimeters to Feet		3.281×10^{-2}
Feet to Centimeters		3.048×10^1
Feet to Meters		3.048×10^{-1}
Inches to Centimeters		2.54
Inches to Meters		2.54×10^{-2}
Inches to Millimeters		2.54×10^1
Inches to Mils		1.00×10^3
Kilometers to Miles		6.214×10^{-1}
Meters to Feet		3.2808
Meters to Inches		3.937×10^1
Meters to Yards		1.0936
Miles to Kilometers		1.6039
Millimeters to Inches		3.937×10^{-2}
Millimeters to Mils		3.937×10^1
Mils to Inches		1.00×10^{-3}
Mils to Millimeters		2.54×10^{-2}
Yards to Meters		9.144×10^{-1}
Weight		Multiply By
Ounces to Pounds		6.25×10^{-2}
Ounces to Grams		2.8349×10^1
Pounds to Ounces		1.6×10^1
Pounds to Grams		4.5359×10^2
Grams to Ounces		3.527×10^{-2}
Grams to Pounds		2.205×10^{-3}
Temperature		Multiply By
Fahrenheit to Centigrade	$^{\circ}\text{F} - 32$	0.555
Centigrade to Fahrenheit	$^{\circ}\text{C} + 17.78$	1.80
Centigrade to Kelvin	$^{\circ}\text{C} + 273$	1.0

1. Introduction – Metric System

The adoption by NASA of the metric system for dimensioning, to replace the long-used English units, imposes a requirement on the U.S. transformer designer to convert from the familiar units to the less familiar metric equivalents. The material in Table 1 is intended to assist in the transition, in the field of transformer design and fabrication. The conversion data makes it possible for the designer to obtain a fast and close approximation of significant parameters such as size, weight, and temperature rise. For greater convenience, derivations of some of the parameters are also presented.

2. Conversion Data for Wire Sizes from #10 to #44

Columns A and B in Table 2 give the bare area in the commonly used circular mils notation, and in the metric equivalent for each wire size. Column C gives the equivalent resistance in microhms/centimeter ($\mu\Omega/\text{cm}$ or $10^{-6} \Omega/\text{cm}$). Columns D to L relate to coated wires showing the effect of insulation on size and the number of turns, and the total weight in grams/centimeter.

The total resistance for a given winding may be calculated by multiplying the MLT (mean length/turn) of the winding in centimeters, by the microhms/cm for the appropriate wire size, and the total number of turns. Thus:

$$R = (\text{MLT}) \times \left(\frac{\mu\Omega}{\text{cm}} \right) \times (N)$$

The weight of the copper in a given winding may be calculated by multiplying the MLT by the grams/cm (column L), and by the total number of turns. Thus:

$$\text{wt} = (\text{MLT}) \times \left(\frac{\text{gm}}{\text{cm}} \right) \times (N)$$

Turns per square inch and turns per square cm are based on 60% wire fill factor.

Table 2. Wire Table

AWG Wire Size	Bare Area		Resistance	Heavy Synthetics								
	cm ² 10 ⁻³ (footnote b)	Cir-Mil ^a	10 ⁻⁶ Ω	Area		Diameter		Turns-Per:		Turns-Per:		Weight gm/cm
			cm at 20°C	cm ² 10 ⁻³	Cir-Mil ^a	cm	Inch ^a	cm	Inch ^a	cm ²	Inch ²	
10	52.61	10384	32.70	55.9	11046	0.267	0.1051	3.87	9.5	10.73	69.20	0.468
11	41.68	8226	41.37	44.5	8798	0.238	0.0938	4.36	10.7	13.48	89.95	0.3750
12	33.08	6529	52.09	35.64	7022	0.213	0.0838	4.85	11.9	16.81	108.4	0.2977
13	26.26	5184	65.64	28.36	5610	0.190	0.0749	5.47	13.4	21.15	136.4	0.2367
14	20.82	4109	82.80	22.95	4556	0.171	0.0675	6.04	14.8	26.14	168.6	0.1879
15	16.51	3260	104.3	18.37	3624	0.153	0.0602	6.77	16.6	32.66	210.6	0.1492
16	13.07	2581	131.8	14.73	2905	0.137	0.0539	7.32	18.6	40.73	262.7	0.1184
17	10.39	2052	165.8	11.68	2323	0.122	0.0482	8.18	20.8	51.36	331.2	0.0943
18	8.228	1624	209.5	9.326	1857	0.109	0.0431	9.13	23.2	64.33	414.9	0.07472
19	6.531	1289	263.9	7.539	1490	0.0980	0.0386	10.19	25.9	79.85	515.0	0.05940
20	5.188	1024	332.3	6.065	1197	0.0879	0.0346	11.37	28.9	98.93	638.1	0.04726
21	4.116	812.3	418.9	4.837	954.8	0.0785	0.0309	12.75	32.4	124.0	799.8	0.03757
22	3.243	640.1	531.4	3.857	761.7	0.0701	0.0276	14.25	36.2	155.5	1003	0.02965
23	2.588	510.8	666.0	3.135	620.0	0.0632	0.0249	15.82	40.2	191.3	1234	0.02372
24	2.047	404.0	842.1	2.514	497.3	0.0566	0.0223	17.63	44.8	238.6	1539	0.01884
25	1.623	320.4	1062.0	2.002	396.0	0.0505	0.0199	19.80	50.3	299.7	1933	0.01498
26	1.280	252.8	1345.0	1.603	316.8	0.0452	0.0178	22.12	56.2	374.2	2414	0.01185
27	1.021	201.6	1687.6	1.313	259.2	0.0409	0.0161	24.44	62.1	456.9	2947	0.00945
28	0.8046	158.8	2142.7	1.0515	207.3	0.0366	0.0144	27.32	69.4	570.6	3680	0.00747
29	0.6470	127.7	2664.3	0.8548	169.0	0.0330	0.0130	30.27	76.9	701.9	4527	0.00602
30	0.5067	100.0	3402.2	0.6785	134.5	0.0294	0.0116	33.93	86.2	884.3	5703	0.00472
31	0.4013	79.21	4294.6	0.5596	110.2	0.0267	0.0105	37.48	95.2	1072	6914	0.00372
32	0.3242	64.00	5314.9	0.4559	90.25	0.0241	0.0095	41.45	105.3	1316	8488	0.00305
33	0.2554	50.41	6748.6	0.3662	72.25	0.0216	0.0085	46.33	117.7	1638	10565	0.00241
34	0.2011	39.69	8572.8	0.2863	56.25	0.0191	0.0075	52.48	133.3	2095	13512	0.00189
35	0.1589	31.36	10849	0.2268	44.89	0.0170	0.0067	58.77	149.3	2645	17060	0.00150
36	0.1266	25.00	13608	0.1813	36.00	0.0152	0.0060	65.62	166.7	3309	21343	0.00119
37	0.1026	20.25	16801	0.1538	30.25	0.0140	0.0055	71.57	181.8	3901	25161	0.000977
38	0.08107	16.00	21266	0.1207	24.01	0.0124	0.0049	80.35	204.1	4971	32062	0.000773
39	0.06207	12.25	27775	0.0932	18.49	0.0109	0.0043	91.57	232.6	6437	41518	0.000593
40	0.04869	9.61	35400	0.0723	14.44	0.0096	0.0038	103.6	263.2	8298	53522	0.000464
41	0.03972	7.84	43405	0.0584	11.56	0.00863	0.0034	115.7	294.1	10273	66260	0.000379
42	0.03166	6.25	54429	0.04558	9.00	0.00762	0.0030	131.2	333.3	13163	84901	0.000299
43	0.02452	4.84	70308	0.03683	7.29	0.00685	0.0027	145.8	370.4	16291	105076	0.000233
44	0.0202	4.00	85072	0.03165	6.25	0.00635	0.0025	157.4	400.0	18957	122272	0.000195

A

B

C

D

E

F

G

H

I

J

K

L

^a This data from REA Magnetic Wire Datalator (Ref. 1).

^b This notation means the entry in the column must be multiplied by 10⁻³

3. Temperature Correction Factors

The values shown in Fig. 1 are based upon a correction factor of 1.0 at 20°C. For other temperatures, the effect upon wire resistance can be calculated by multiplying the resistance value for the wire size shown in column C of Table 2, by the appropriate correction factor shown on the graph. Thus, Corrected Resistance = $\mu\Omega/\text{cm}$ (at 20°C) $\times \zeta$.

Fig. 1 Resistance Correction Factor (ζ , Zeta) for wire temperature between -50° and +100° C.

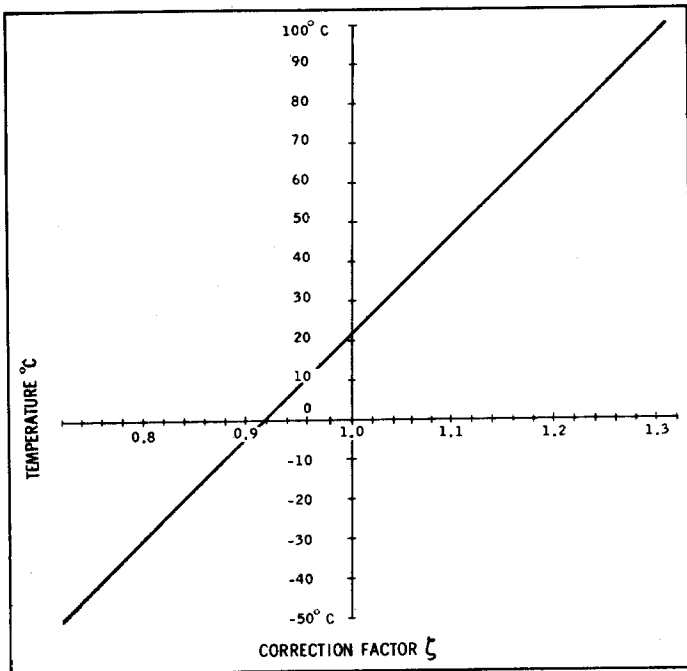

4. Toroidal Fill Factors

Figures 2, 3 and 4 have been devised to assist the engineer in optimizing the dimension of the window in the toroidal core. Available window area for winding turns is affected by:

- (1) Minimum window diameter which may be safely wound.
- (2) Total space occupied by wire (copper and insulation).

The fraction of the available window space which will be occupied by the copper may be calculated from:

$$K = \frac{\text{conductor cm}^2}{\text{wire cm}^2} \times \frac{\text{wound cm}^2}{\text{usable window cm}^2} \times \frac{\text{usable window cm}^2}{\text{window cm}^2}$$

Where:

conductor cm ²	= copper cm ²
wire cm ²	= copper cm ² + insulation cm ²
wound cm ²	= number of turns \times wire area of one turn
usable window cm ²	= available window area minus residual area which results from the particular winding technique used
window area	= available window cm ²

The term conductor cm²/wire cm² (=K₁) is dependent upon wire size. Typical values which may be calculated from the data of Table 2, Columns A and D are:

$$\text{AWG 10} = \frac{52.61 \text{ cm}}{55.90 \text{ cm}} = 0.941$$

$$\text{AWG 20} = \frac{5.188 \text{ cm}}{6.065 \text{ cm}} = 0.855$$

$$\text{AWG 30} = \frac{0.5067 \text{ cm}}{0.6785 \text{ cm}} = 0.747$$

$$\text{AWG 40} = \frac{0.04869 \text{ cm}}{0.0723 \text{ cm}} = 0.673$$

The term wound cm^2 /usable window cm^2 ($=K_2$) is the fill factor for the usable window area. It can be shown theoretically, that for circular cross-section wire wound on a flat form, that the ratio of wire cm^2 to the area required for the turns can never be greater than 0.91. In practice, the actual maximum value is dependent upon the tightness of winding, variations in insulation thickness, and wire lay. Consequently, the fill factor is always less than the theoretical maximum.

Magnetics' Design Manual TWC-300 indicates that random wound cores can be produced with fill factors as high as 0.7, but that progressive sector wound cores can be produced with fill factors of only up to 0.55. The charts of Figures 2, 3 and 4 are based upon fill factor ratios of 0.50, 0.60 and 0.70, respectively. As a typical working value for copper wire with a heavy synthetic film insulation, a ratio of 0.60 may be used safely.

The term usable window cm^2 /window cm^2 ($=K_3$) defines how much of the available window space may actually be used for the winding. The charts are based on the assumption that the inside diameter of the wound core is one-half that of the bare core, i.e. $K_3 = 0.75$ (to allow free passage of the shuttle).

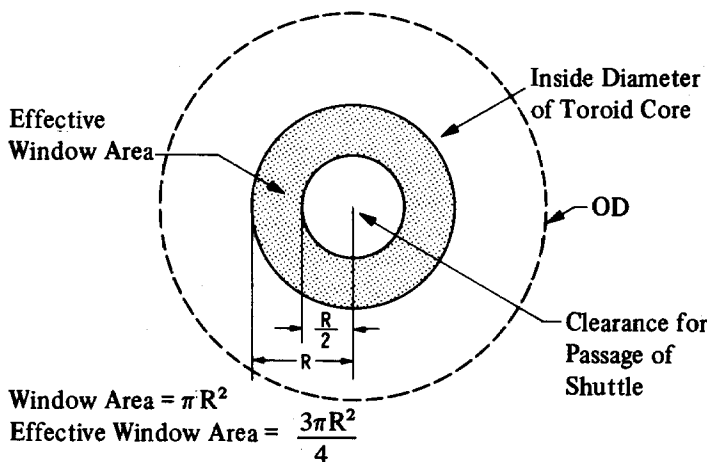

A typical value for the copper fraction in the window area is about 0.40. For example, for AWG 20 wire, $K_1 \times K_2 \times K_3 = 0.855 \times 0.60 \times 0.75 = 0.385$.

Fig. 2. Fill Factor 0.5

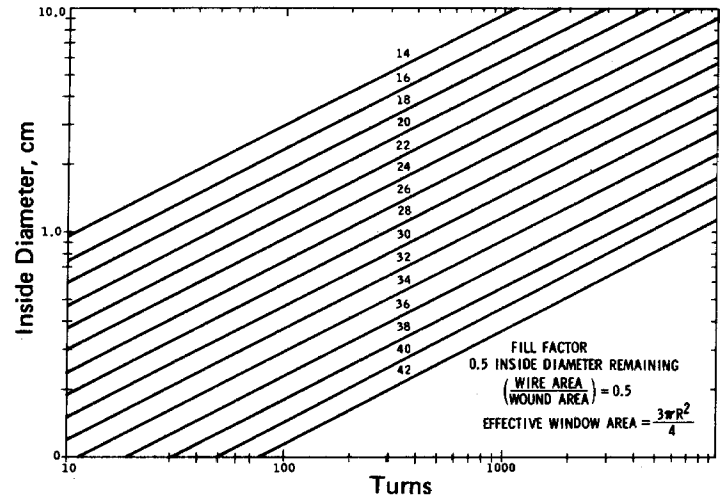

Fig. 3. Fill Factor 0.6

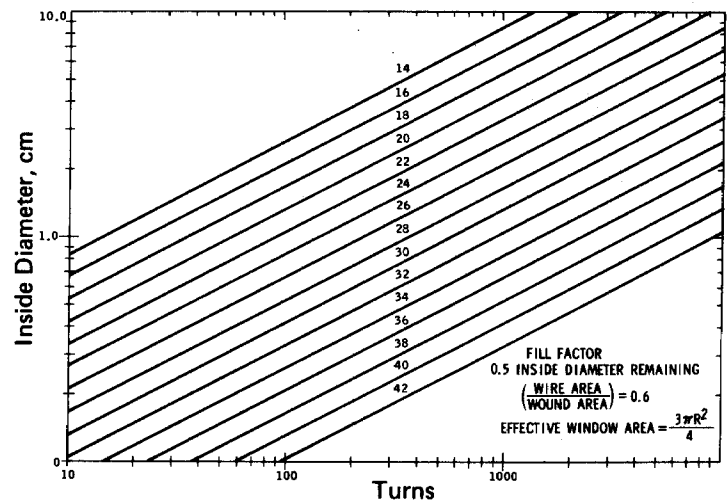
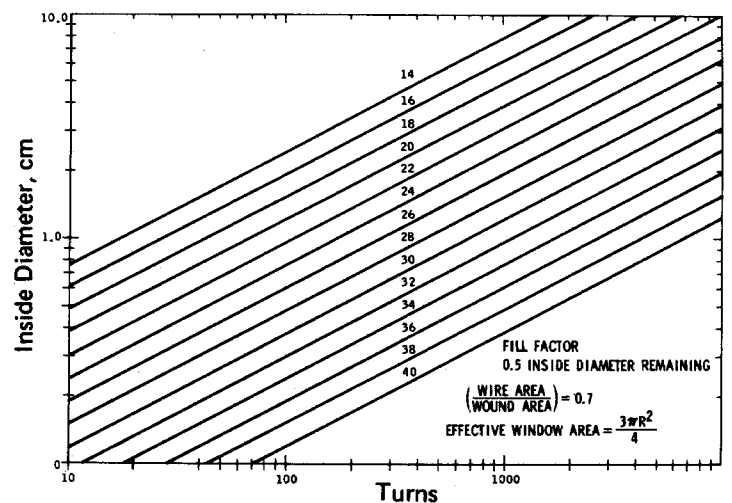

Fig. 4. Fill Factor 0.7



5. Core Size Selection

Upon selecting the transformer core material and material thickness, the next step is to select the proper size core for a transformer with a given operating frequency and output power. The power handling capability of a transformer can be determined by its $W_a A_c$ product, where W_a is the available core window area in cm^2 , and A_c is the core effective cross-sectional area in cm^2 .

The $W_a A_c$ relationships are obtained by solving Faraday's Law in the following manner:

Faraday's Law = $E = 4B_m A_c N f \times 10^{-4}$ (square wave)

$$E = 4.44B_m A_c N f \times 10^{-4} \text{ (sine wave)}$$

Where:

E	=	applied voltage (rms)
B_m	=	flux density in teslas
A_c	=	core effective cross-sectional area in cm^2
N	=	number of turns
f	=	frequency in Hz
A_w	=	bare wire area in cm^2
W_a	=	window area in cm^2
K	=	window utilization factor
I	=	current (rms)
J	=	current density
P_o	=	output power (total)
P_1	=	input power
P_T	=	total power
η	=	efficiency

Solving for:

$$N A_c = \frac{E \times 10^4}{4B_m f}$$

Window utilization factor:

$$K = \frac{N A_w}{W_a}$$

$$N = \frac{K W_a}{A_w}$$

Multiply both sides by A_c :

$$N A_c = \frac{K W_a A_c}{A_w} = \frac{E \times 10^4}{4B_m f}$$

Combining and solving for $W_a A_c$:

$$\frac{K W_a A_c}{A_w} = \frac{E \times 10^4}{4B_m f K}$$

$$W_a A_c = \frac{E A_w \times 10^4}{4B_m f K}$$

$$J = \frac{I}{A_w} = \frac{\text{Amp}}{\text{cm}^2}$$

$$\eta = \frac{P_o}{P_1}$$

$$P_1 = E I$$

$$E A_w = \frac{E I}{J} = \frac{P_1}{J} = \frac{P_o}{J \eta}$$

$$W_a A_c \left|_{(total)} = W_a A_c \left|_{(primary)} + W_a A_c \left|_{(secondary)} \right. \right.$$

$$W_a A_c \left|_{(total)} = \frac{P_o}{J} \times \frac{10^4}{4B_m f K} + \frac{P_o 10^4}{4B_m f K J} = \frac{P_o 10^4}{4B_m f K J} (1/\eta + 1)$$

$$P_T = \frac{P_o}{\eta} + P_o$$

$$W_a A_c = \frac{P_T \times 10^4}{4B_m f K J}$$

Window utilization factor K:

$$\left. \begin{array}{l} \text{Lamination and Bobbin} \\ \text{Toroid 1/2 ID remaining} \\ \text{C Core and Bobbin} \end{array} \right\} \frac{W_a (\text{eff.})}{W_a} \times \text{Fill Factor} \times \frac{A_w \text{ Bare}}{A_w \text{ Total}} = 0.4$$

$$W_a A_c = \frac{P_T \times 10^4}{1.6 \times B_m f J} \text{ square wave}$$

$$W_a A_c = \frac{P_T \times 10^4}{1.77 \times B_m f J} \text{ sine wave}$$

The curve in Fig. 5 shows the required core $Wa Ac$ product plotted against transformer output power for different frequency. The values held constant were:

$$B_m = 0.3 \text{ T}$$

$$J = 200 \text{ Amps/cm}^2$$

$$K = 0.40$$

$$\eta = 95\%$$

These values were held constant so that one nomograph could be used with all materials and the engineer could adjust B_m , J , K and η to fit the design. From the equation:

$$Wa Ac = \frac{P_T \times 10^4}{1.6 \times B_m f J}$$

two nomographs were generated to compare output power

$$P_o = \frac{P_T}{(1/\eta + 1)}$$

with $Wa Ac$ and P_o with weight. These nomographs were generated from the lamination and C core in the article. The nomograph in Fig. 5 compares P_o with $Wa Ac$, thus the size of the transformer can quickly be determined. The nomograph in Fig. 6 compares power with weight, thus the weight of a fully wound transformer can quickly be determined. These nomographs have the following constraints:

$$B_m = 0.3 \text{ T}$$

$$J = 200 \text{ A/cm}^2$$

$$K = 0.4$$

Very likely, after the $Wa Ac$ has been selected, a slight adjustment of the constraints is required to correspond to the actual core $Wa Ac$ products available.

Fig. 5 $Wa Ac$ versus Output Power

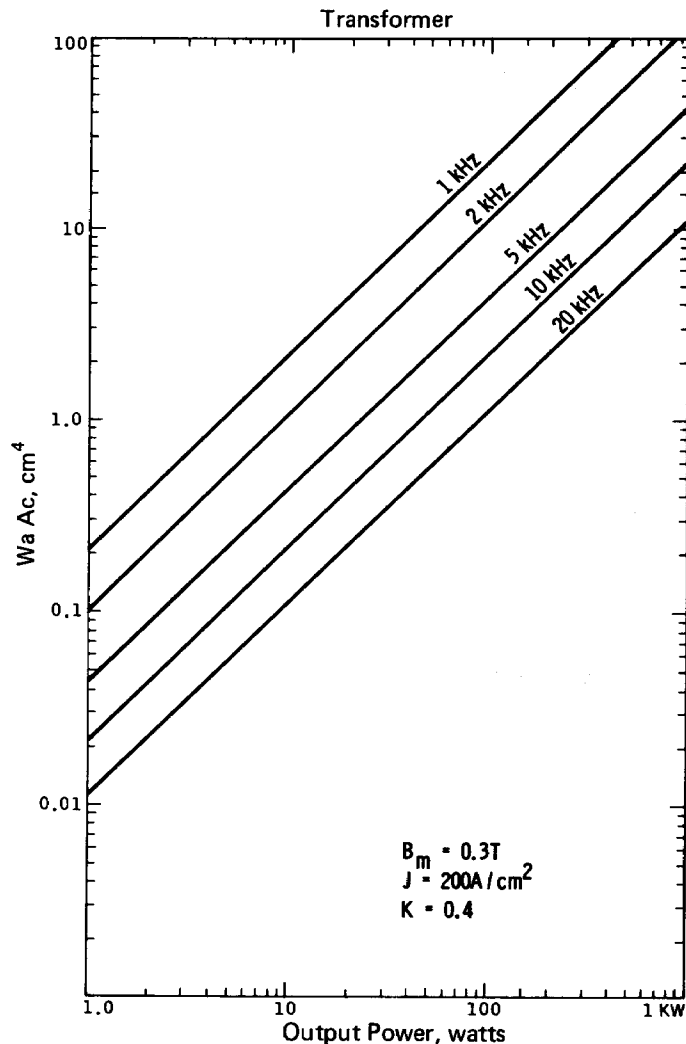
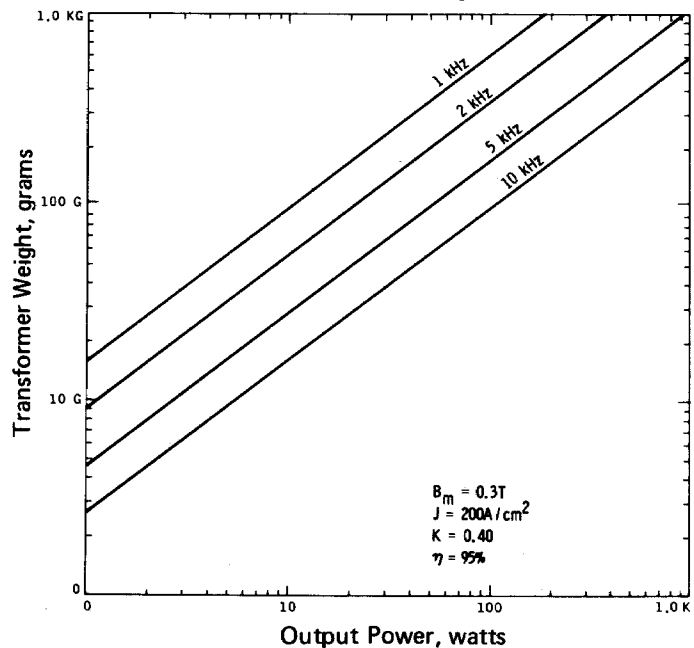

Fig. 6 Transformer Weight versus Output Power



6. Toroid Powder Core Selection with DC Current

After calculating the inductance and DC current, select the proper permeability and size powder core with a given $LI^2/2$. The energy handling capability of an inductor can be determined by its $Wa Ac$ product, where Wa is the available core window area in cm^2 , and Ac is the core effective cross-sectional area cm^2 . The $Wa Ac$ relationship is obtained by solving $E = L \, dI/dt$ as follows:

Where:

E = voltage, volts	H' = magnetizing force, amp turns/m
L = inductance, henries	ℓ_m' = magnetic path length, m
I = current, amperes	K = window utilization factor
N = number of turns	Wa' = window area, m^2
ϕ = flux, webers	J' = current density, amps/ m^2
B_m = flux density, teslas	Eng = energy, watt seconds
Ac' = core cross-section, m^2	
μ_r = relative permeability	
μ_o = absolute permeability ($4\pi \times 10^{-7}$)	

$$E = L \frac{dI}{dt} = N \frac{d\phi}{dt}$$

$$L = N \frac{d\phi}{dI}$$

$$\phi = B_m Ac'$$

$$B_m = \mu_r \mu_o H' = \frac{\mu_r \mu_o NI}{\ell_m'}$$

$$\phi = \frac{\mu_r \mu_o NI Ac'}{\ell_m'}$$

$$\frac{d\phi}{dI} = \frac{\mu_r \mu_o N Ac'}{\ell_m'}$$

$$L = N \frac{d\phi}{dI} = \frac{\mu_r \mu_o N^2 Ac'}{\ell_m'}$$

$$Energy = \frac{1}{2} LI^2 = \frac{\mu_r \mu_o N^2 Ac'}{2 \ell_m'} I^2$$

If B_m is specified,

$$I = \frac{B_m \ell_m'}{\mu_r \mu_o N}$$

$$Eng = \frac{\mu_r \mu_o N^2 Ac'}{2 \ell_m'} \left(\frac{B_m \ell_m'}{\mu_r \mu_o N} \right)^2 = \frac{(B_m)^2 \ell_m' Ac'}{2 \mu_r \mu_o} \text{ watt seconds}$$

$$I = \frac{K Wa' J'}{N} = \frac{B_m \ell_m'}{\mu_r \mu_o N}$$

Solving for $\mu_r \mu_o$,

$$\mu_r \mu_o = \frac{B_m \ell_m'}{K Wa' J'}$$

Substituting into the energy equation:

$$Eng = \frac{(B_m)^2 \ell_m' Ac'}{2} \times \frac{K Wa' J'}{B_m \ell_m'} = \frac{Wa' Ac' B_m J' K}{2}$$

Let:

Wa = window area, cm^2
Ac = core area, cm^2
J = current density, amps/ cm^2
$Wa' = Wa \times 10^{-4}$
$Ac' = Ac \times 10^{-4}$
$J' = J \times 10^4$

Substituting into the energy equation:

$$Eng = \frac{Wa Ac B_m JK}{2} \times 10^{-4}$$

Solving for $Wa Ac$,

$$Wa Ac = \frac{2 (Eng)}{B_m JK} \times 10^4$$

let:

ℓ_m = magnetic path length, cm

$$\ell_m' = \ell_m \times 10^{-2}$$

$$\mu_r = \frac{B_m \ell_m \times 10^{-2}}{K \mu_o (Wa \times 10^{-4}) (J \times 10^4)} = \frac{B_m \ell_m \times 10^{-2}}{\mu_o Wa JK}$$

for $\mu_o = 4\pi \times 10^{-7}$,

$$\mu_r = \frac{B_m \ell_m \times 10^{-2}}{4\pi \times 10^{-7} Wa JK} = \frac{B_m \ell_m \times 10^4}{0.4 Wa JK}$$

From the equation:

$$Wa Ac = \frac{2 (Eng)}{B_m JK} \times 10^4$$

two nomographs were generated to compare energy or $LI^2/2$ with $Wa Ac$ and energy or $LI^2/2$ with weight. These nomographs were generated for 13 commonly used powder cores in this article. The nomograph in Fig. 7 compares $LI^2/2$ with $Wa Ac$, thus the size of an inductor can quickly be determined. The nomograph in Fig. 8 compares $LI^2/2$ with weight, thus the weight of a fully wound inductor can quickly be determined. These nomographs have the following constraints:

$$B_m = 0.3 \text{ T}$$

$$J = 200 \text{ A/cm}^2$$

$$K = 0.4$$

After the core size has been determined, the next step is to pick the right permeability for that core size, using the following equation:

$$\mu_r = \frac{B_m \ell_m \times 10^4}{0.4\pi W_a J K}$$

Very likely, after the permeability has been selected, a slight adjustment of the constraints to match the available core sizes and permeabilities must be made.

Fig. 7. $W_a A_c$ versus $LI^2/2$

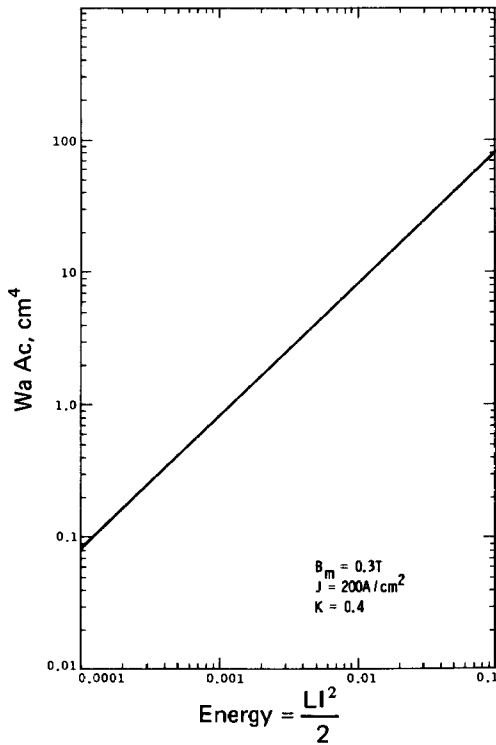
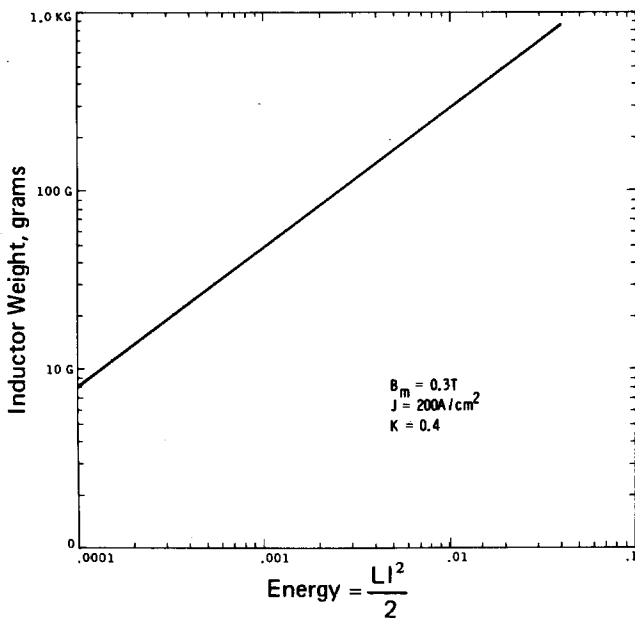

Fig. 8. Inductor Weight versus $LI^2/2$



7. Calculation of Outside Diameter of Wound Toroid

The outside diameter of the wound toroid, Fig. 9, (less the outside wrapper) may be calculated from the following equation (assuming one half of the ID remains after winding):

$$OD = \sqrt{D_b^2 (\frac{3}{4}) + D_c^2} \quad (D = \text{diameter})$$

Where:

$$A_1 = \pi (R_b^2 - R_a^2), \quad A_1 = A_2$$

$$\text{Core window ID} = D_a = 2R_a, \quad \text{Core ID} = D_b = 2R_b,$$

$$\text{Core OD} = D_c = 2R_c$$

$$\pi (R_b^2 - R_a^2) = \pi (R_d^2 - R_c^2), \quad R_b^2 - R_a^2 = R_d^2 - R_c^2,$$

$$R_a = \frac{R_b}{2}$$

$$R_d^2 - R_c^2 = R_b^2 - \left(\frac{R_b}{2}\right)^2 = R_b^2 (1 - \frac{1}{4}), \quad R_d^2 = R_b^2 (\frac{3}{4}) + R_c^2$$

$$R_d = \sqrt{R_b^2 (\frac{3}{4}) + R_c^2}$$

$$OD = 2 R_d$$

Fig. 9. Calculation of Outside Diameter of Wound Toroid

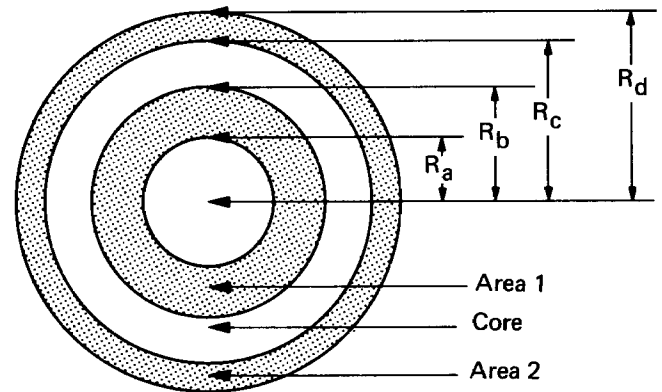

8. Magnetic and Dimensional Specifications for Thirteen Commonly Used Molypermalloy Cores

The following remarks apply to each of Tables 3 to 15, the data in which was compiled from Reference 2.

- (1) Total weight is core weight plus wire weight, assuming AWG 20
- (2) Maximum OD of wound core with residual hole = $\frac{1}{2}$ ID
- (3) MLT (mean length/turn), $K_2 \times K_3 = 0.6 \times 0.75 = 0.45$
- (4) Effective window area, $W_{a \text{ eff}} = 3\pi r^2 / 4$

Data was computed with the aid of manuals listed in References 2 and 3, page 37.

Nomographs (Figures 10 to 22) relate to the thirteen different core sizes. The nomographs show resistance, number of turns, inductance and wire size for a fill factor of 0.45 ($K_2 \times K_3$), and are based on a permeability of 60. To convert for other permeability values, the appropriate inductance multiplication factors listed should be used. The information appearing in the tables and on the figures will enable the engineer to arrive at a close approximation for breadboarding purposes.

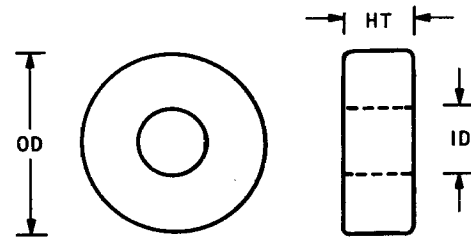

This Figure can be used as a guide for Tables 3 through 15.

Fig. 10. Nomograph for Core 55051-A2

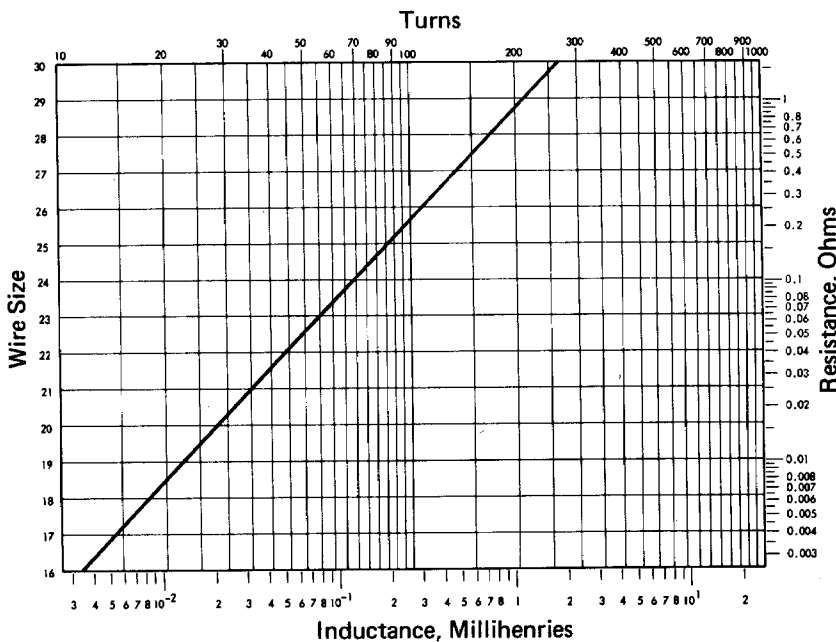

Table 3. Magnetics 55051-A2

	English	Metric
Wa/Ac		3.39
Wa × Ac	0.00104 in ⁴	0.0432 cm ⁴
OD	0.530 in	1.346 cm
ID	0.275 in	0.699 cm
HT	0.217 in	0.551 cm
Wa = Window Area	0.075 × 10 ⁶ cir-mil	0.383 cm ²
Wa = Effective	0.445 in ²	0.288 cm ²
Ac = Cross Section	0.0175 in ²	0.113 cm ²
ℓ _m = Path Length	1.229 in	3.12 cm
Core Weight	0.0066 lb	3.0 grams
Total Weight	0.0106 lb	5.175 grams
Wound OD Min	0.581 in	1.475 cm
MLT	0.850 in	2.160 cm
A _t = Surface Area	1.018 in ²	6.568 cm ²
Permeability		60
μ 125		2.08 × L @ μ 60
μ 160		2.67 × L @ μ 60
μ 200		3.33 × L @ μ 60
μ 550		9.17 × L @ μ 60

Fig. 11. Nomograph for Core 55121-A2

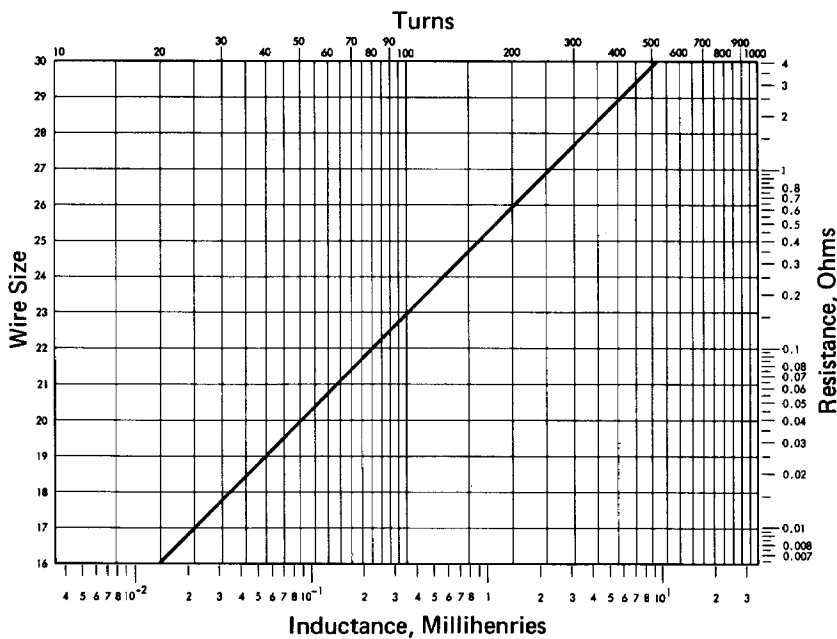

Table 4. Magnetics 55121-A2

	English	Metric
Wa/Ac		3.63
Wa × Ac	0.00336 in ⁴	0.139 cm ⁴
OD	0.680 in	1.740 cm
ID	0.375 in	0.953 cm
HT	0.280 in	0.711 cm
Wa = Window Area	0.141 × 10 ⁶ cir-mil	0.713 cm ²
Wa = Effective	0.0828 in ²	0.535 cm ²
Ac = Cross Section	0.0304 in ²	0.196 cm ²
ℓ _m = Path Length	1.62 in	4.11 cm
Core Weight	0.0143 lb	6.50 grams
Total Weight	0.0257 lb	11.70 grams
Wound OD Min	0.753 in	1.925 cm
MLT	1.075 in	2.74 cm
A _t = Surface Area	1.742 in ²	11.24 cm ²
Permeability		60
μ 125		2.08 × L @ μ 60
μ 160		2.67 × L @ μ 60
μ 200		3.33 × L @ μ 60
μ 550		9.17 × L @ μ 60

Fig. 12. Nomograph for Core 55848-A2

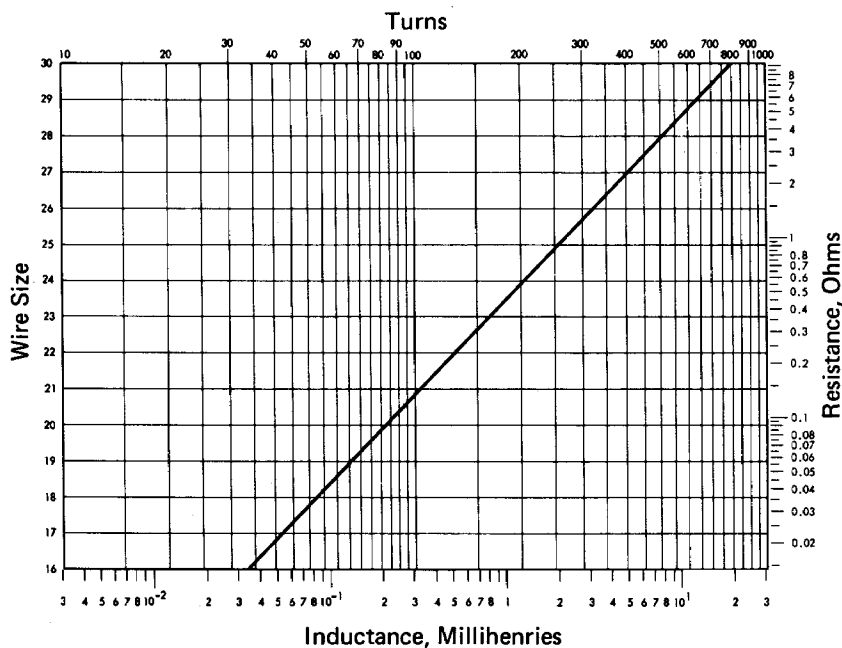

Table 5. Magnetics 55848-A2

	English	Metric
Wa/Ac		4.91
Wa × Ac	0.00636 in ⁴	0.264 cm ⁴
OD	0.830 in	2.11 cm
ID	0.475 in	1.21 cm
HT	0.280 in	0.711 cm
Wa = Window Area	0.23 × 10 ⁶ cir-mil	1.14 cm ²
Wa = Effective	0.13290 in ²	0.858 cm ²
Ac = Cross Section	0.036 in ²	0.232 cm ²
ℓ _m = Path Length	2.01 in	5.09 cm
Core Weight	0.021 lb	9.6 grams
Total Weight	0.041 lb	18.6 grams
Wound OD Min	0.926 in	2.35 cm
MLT	1.166 in	2.97 cm
A _t = Surface Area	2.431 in ²	15.69 cm ²
Permeability		60
μ 125		2.08 × L @ μ 60
μ 160		2.67 × L @ μ 60
μ 200		3.33 × L @ μ 60
μ 550		9.17 × L @ μ 60

Fig. 13. Nomograph for Core 55059-A2

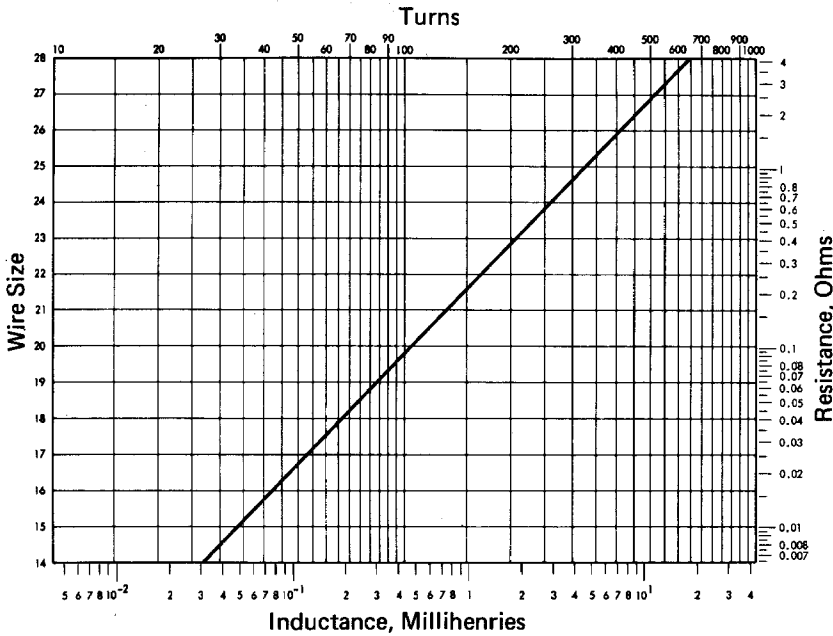

Table 6. Magnetics 55059-A2

	English	Metric
Wa/Ac		4.30
Wa X Ac	0.0713 in ⁴	0.460 cm ⁴
OD	0.930 in	2.36 cm
ID	0.527 in	1.339 cm
HT	0.330 in	0.838 cm
Wa = Window Area	0.28 X 10 ⁶ cir-mil	1.407 cm ²
Wa = Effective	0.164 in ²	1.056 cm ²
Ac = Cross Section	0.0507 in ²	0.327 cm ²
ℓ _m = Path Length	2.23 in	5.67 cm
Core Weight	0.033 lb	15.0 grams
Total Weight	0.0716 lb	32.5 grams
Wound OD Min	1.035 in	2.63 cm
MLT	1.356 in	3.45 cm
A _t = Surface Area	3.103 in ²	20.019 cm ²
Permeability		60
μ 125		2.08 X L @ μ 60
μ 160		2.67 X L @ μ 60
μ 200		3.33 X L @ μ 60
μ 550		9.17 X L @ μ 60

Fig. 14. Nomograph for Core 55894-A2

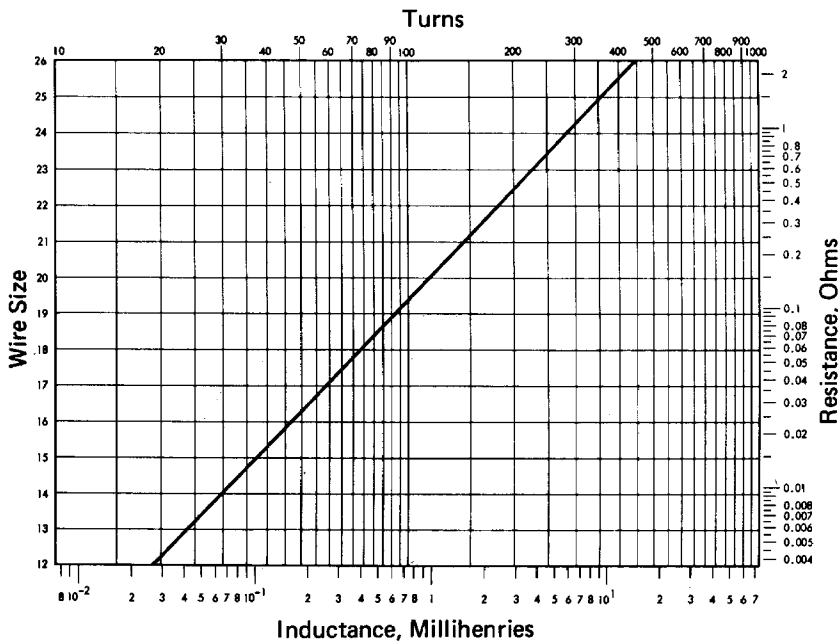

Table 7. Magnetics 55894-A2

	English	Metric
Wa/Ac		2.44
Wa X Ac	0.0239 in ⁴	0.997 cm ⁴
OD	1.090 in	2.77 cm
ID	0.555 in	1.41 cm
HT	0.472 in	1.20 cm
Wa = Window Area	0.31 X 10 ⁶ cir-mil	1.561 cm ²
Wa = Effective	0.1814 in ²	1.17 cm ²
Ac = Cross Section	0.099 in ²	0.639 cm ²
ℓ _m = Path Length	2.50 in	6.35 cm
Core Weight	0.077 lb	35 grams
Total Weight	0.132 lb	59.7 grams
Wound OD Min	1.191 in	3.03 cm
MLT	1.81 in	4.61 cm
A _t = Surface Area	4.39 in ²	28.32 cm ²
Permeability		60
μ 125		2.08 X L @ μ 60
μ 160		2.67 X L @ μ 60
μ 200		3.33 X L @ μ 60
μ 550		9.17 X L @ μ 60

Fig. 15. Nomograph for Core 55071-A2

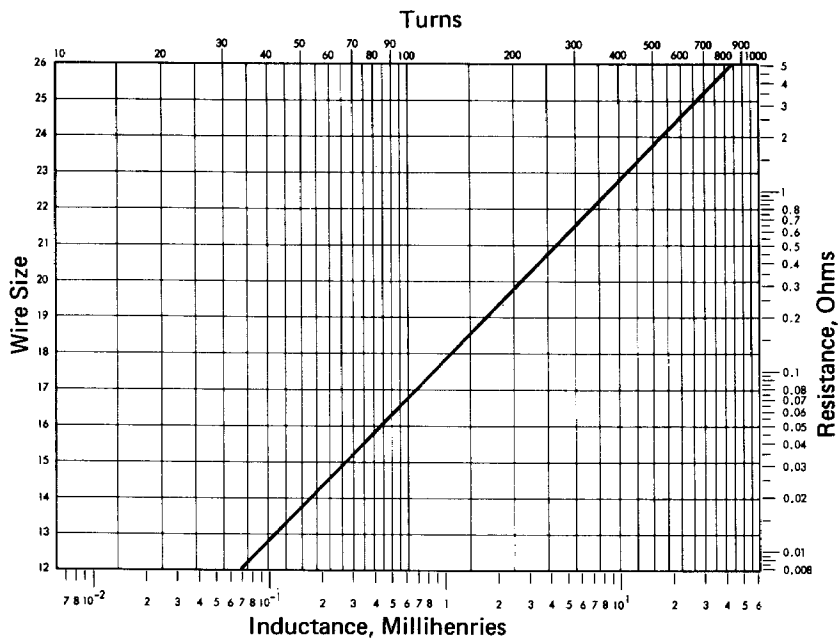

Table 8. Magnetics 55071-A2

	English	Metric
Wa/Ac		4.39
Wa × Ac	0.0468 in ⁴	1.95 cm ⁴
OD	1.332 in	3.38 cm
ID	0.760 in	1.93 cm
HT	0.457 in	1.16 cm
Wa = Window Area	0.58 × 10 ⁶ cir-mil	2.93 cm ²
Wa = Effective	0.340 in ²	2.1941 cm ²
Ac = Cross Section	0.1032 in ²	0.666 cm ²
ℓ _m = Path Length	3.21 in	8.15 cm
Core Weight	0.101 lb	46 grams
Total Weight	0.198 lb	90 grams
Wound OD Min	1.486 in	3.77 cm
MLT	1.89 in	4.80 cm
A _t = Surface Area	6.305 in ²	40.68 cm ²
Permeability		60
μ 125		2.08 × L @ μ 60
μ 160		2.67 × L @ μ 60
μ 200		3.33 × L @ μ 60
μ 550		9.17 × L @ μ 60

Fig. 16. Nomograph for Core 55586-A2

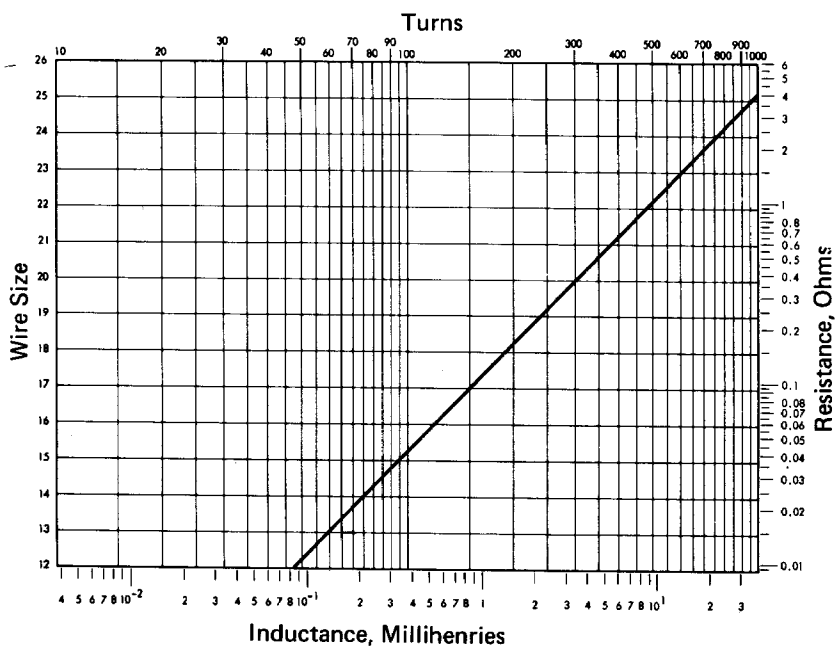

Table 9. Magnetics 55586-A2

	English	Metric
Wa/Ac		8.73
Wa × Ac	0.044 in ⁴	1.832 cm ⁴
OD	1.382 in	3.51 cm
ID	0.888 in	2.26 cm
HT	0.387 in	0.983 cm
Wa = Window Area	0.79 × 10 ⁶ cir-mil	4.00 cm ²
Wa = Effective	0.4644 in ²	3.009 cm ²
Ac = Cross Section	0.0710 in ²	0.458 cm ²
ℓ _m = Path Length	3.53 in	8.95 cm
Core Weight	0.075 lb	34 grams
Total Weight	0.193 lb	87.4 grams
Wound OD Min	1.58 in	4.02 cm
MLT	1.70 in	4.32 cm
A _t = Surface Area	6.86 in ²	44.24 cm ²
Permeability		60
μ 125		2.08 × L @ μ 60
μ 160		2.67 × L @ μ 60
μ 200		3.33 × L @ μ 60
μ 550		9.17 × L @ μ 60

Fig. 17. Nomograph for Core 55076-A2

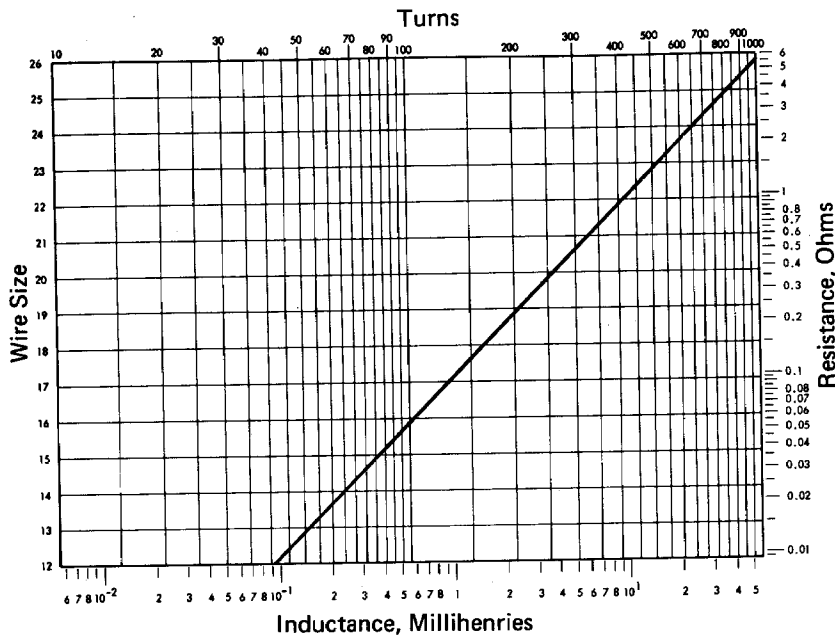

Table 10. Magnetics 55076-A2

	English		Metric	
Wa/Ac			5.43	
Wa × Ac	0.0586	in ⁴	2.44	cm ⁴
OD	1.44	in	3.66	cm
ID	0.848	in	2.15	cm
HT	0.444	in	1.128	cm
Wa = Window Area	0.72 × 10 ⁶ cir-mil		3.64	cm ²
Wa = Effective	0.424	in ²	2.723	cm ²
Ac = Cross Section	0.1039	in ²	0.670	cm ²
ℓ _m = Path Length	3.54	in	8.98	cm
Core Weight	0.112	lb	51	grams
Total Weight	0.239	lb	108.4	grams
Wound OD Min	1.62	in	4.11	cm
MLT	1.91	in	4.88	cm
A _t = Surface Area	7.271	in ²	46.91	cm ²
Permeability			60	
μ 125			2.08 × L @ μ 60	
μ 160			2.67 × L @ μ 60	
μ 200			3.33 × L @ μ 60	
μ 550			9.17 × L @ μ 60	

Fig. 18. Nomograph for Core 55083-A2

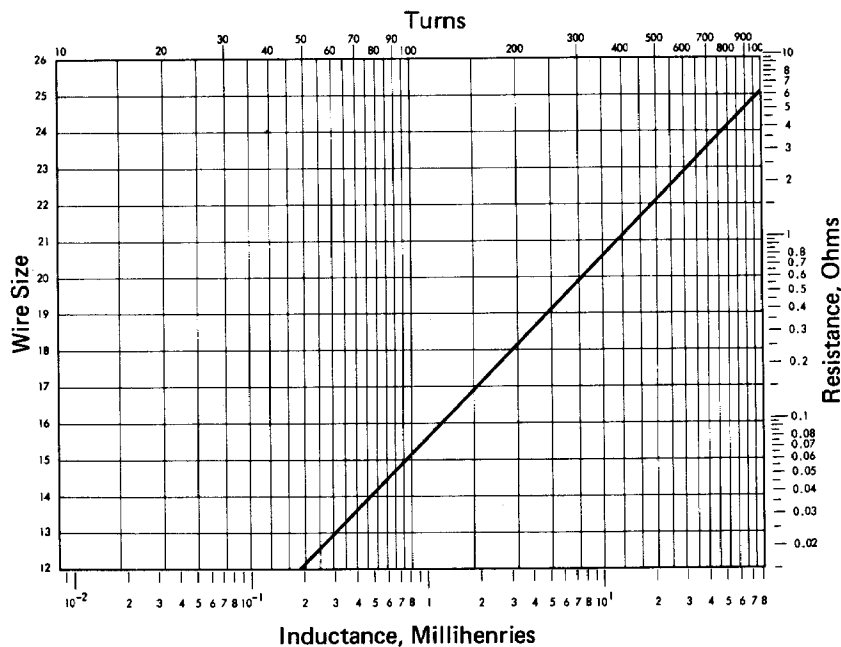

Table 11. Magnetics 55083-A2

	English		Metric	
Wa/Ac			4.02	
Wa × Ac	0.108	in ⁴	4.53	cm ⁴
OD	1.602	in	4.07	cm
ID	0.918	in	2.33	cm
HT	0.605	in	1.54	cm
Wa = Window Area	0.84 × 10 ⁶ cir-mil		4.27	cm ²
Wa = Effective	0.496	in ²	3.198	cm ²
Ac = Cross Section	0.164	in ²	1.06	cm ²
ℓ _m = Path Length	3.88	in	9.84	cm
Core Weight	0.198	lb	90	grams
Total Weight	0.388	lb	176	grams
Wound OD Min	1.79	in	4.54	cm
MLT	2.36	in	6.07	cm
A _t = Surface Area	9.46	in ²	61.05	cm ²
Permeability			60	
μ 125			2.08 × L @ μ 60	
μ 160			2.67 × L @ μ 60	
μ 200			3.33 × L @ μ 60	
μ 550			9.17 × L @ μ 60	

Fig. 19. Nomograph for Core 55439-A2

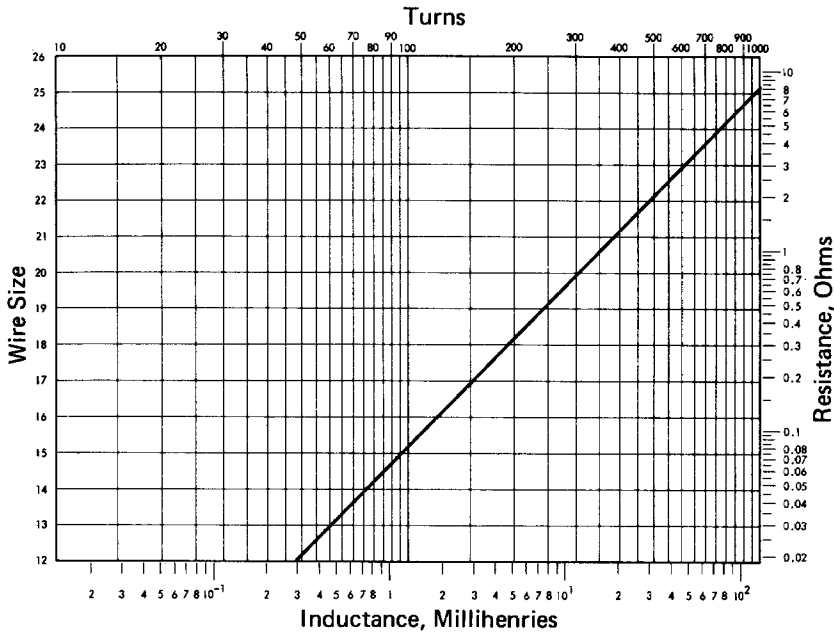

Table 12. Magnetics 55439-A2

	English	Metric
Wa/Ac		2.19
Wa × Ac	0.200 in ⁴	8.33 cm ⁴
OD	1.875 in	4.76 cm
ID	0.918 in	2.33 cm
HT	0.745 in	1.89 cm
Wa = Window Area	0.84 × 10 ⁶ cir-mil	4.27 cm ²
Wa = Effective	0.496 in ²	3.198 cm ²
Ac = Cross Section	0.302 in ²	1.95 cm ²
ℓ _m = Path Length	4.23 in	10.74 cm
Core Weight	0.346 lb	180 grams
Total Weight	0.641 lb	291 grams
Wound OD Min	2.04 in	5.17 cm
MLT	3.00 in	7.62 cm
A _t = Surface Area	12.30 in ²	79.37 cm ²
Permeability		60
μ 125		2.08 × L @ μ 60
μ 160		2.67 × L @ μ 60
μ 200		3.33 × L @ μ 60
μ 550		9.17 × L @ μ 60

Fig. 20. Nomograph for Core 55090-A2

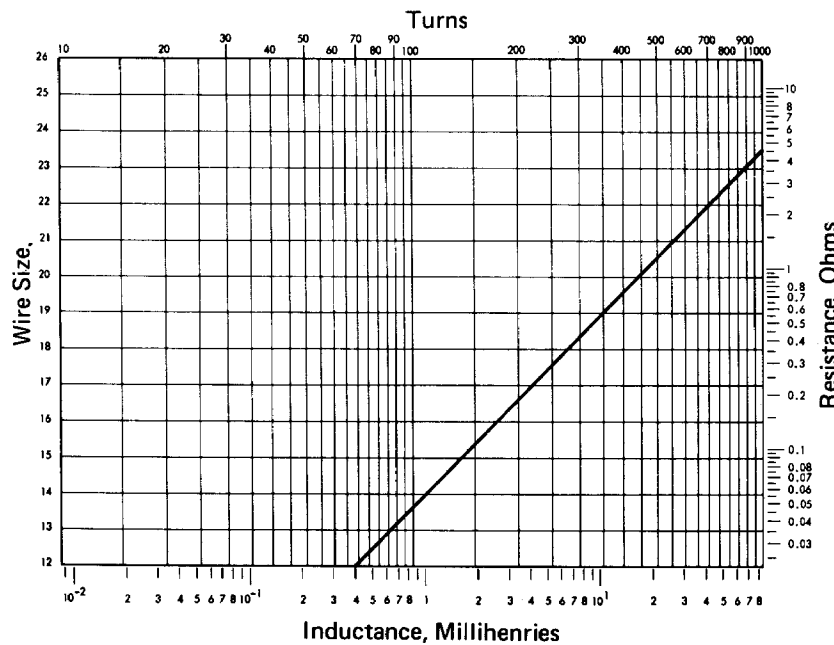

Table 13. Magnetics 55090-A2

	English	Metric
Wa/Ac		4.63
Wa × Ac	0.194 in ⁴	8.06 cm ⁴
OD	1.875 in	4.76 cm
ID	1.098 in	2.79 cm
HT	0.635 in	1.61 cm
Wa = Window Area	1.21 × 10 ⁶ cir-mil	6.11 cm ²
Wa = Effective	0.710 in ²	4.58 cm ²
Ac = Cross Section	0.205 in ²	1.32 cm ²
ℓ _m = Path Length	4.58 in	11.62 cm
Core Weight	0.286 lb	130 grams
Total Weight	0.588 lb	267 grams
Wound OD Min	2.10 in	5.34 cm
MLT	2.62 in	6.66 cm
A _t = Surface Area	12.64 in ²	81.58 cm ²
Permeability		60
μ 125		2.08 × L @ μ 60
μ 160		2.67 × L @ μ 60
μ 200		3.33 × L @ μ 60
μ 550		9.17 × L @ μ 60

Fig. 21. Nomograph for Core 55716-A2

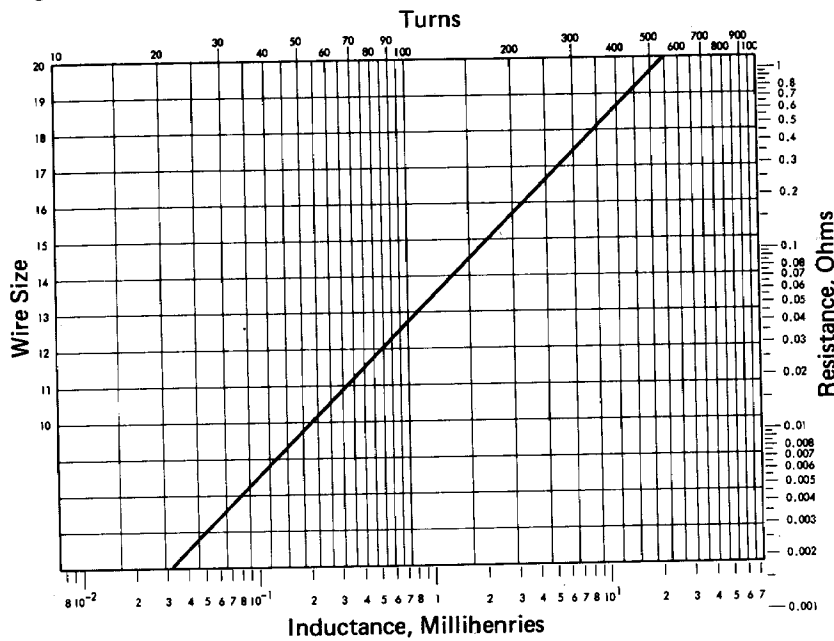

Table 14. Magnetics 55716-A2

	English	Metric
Wa/Ac		6.06
Wa × Ac	0.224 in ⁴	9.32 cm ⁴
OD	2.035 in	5.17 cm
ID	1.218 in	3.09 cm
HT	0.565 in	1.435 cm
Wa = Window Area	1.48 × 10 ⁶ cir-mil	7.52 cm ²
Wa = Effective	0.874 in ²	5.62 cm ²
Ac = Cross Section	0.192 in ²	1.24 cm ²
ℓ _m = Path Length	5.02 in	12.73 cm
Core Weight	0.298 lb	135 grams
Total Weight	0.652 lb	296 grams
Wound OD Min	2.29 in	5.82 cm
MLT	2.55 in	6.50 cm
A _t = Surface Area	14.15 in ²	91.32 cm ²
Permeability		60
μ 125		2.08 × L @ μ 60
μ 160		2.67 × L @ μ 60
μ 200		3.33 × L @ μ 60
μ 550		9.17 × L @ μ 60

Fig. 22. Nomograph for Core 55110-A2

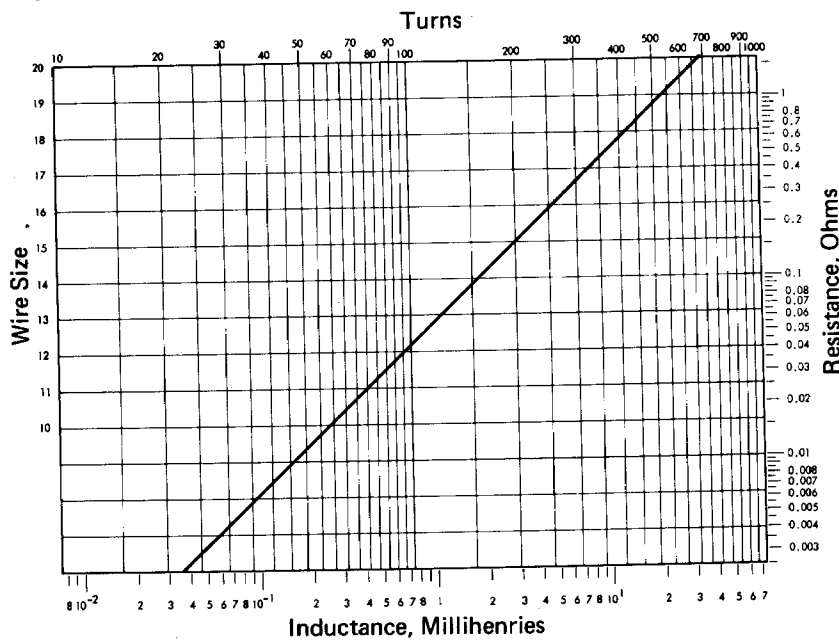

Table 15. Magnetics 55110-A2

	English	Metric
Wa/Ac		6.58
Wa × Ac	0.328 in ⁴	13.65 cm ⁴
OD	2.285 in	5.8 cm
ID	1.368 in	3.47 cm
HT	0.585 in	1.486 cm
Wa = Window Area	1.87 × 10 ⁶ cir-mil	9.48 cm ²
Wa = Effective	1.1023 in ²	7.093 cm ²
Ac = Cross Section	0.223 in ²	1.44 cm ²
ℓ _m = Path Length	5.63 in	14.30 cm
Core Weight	0.385 lb	175 grams
Total Weight	0.864 lb	392 grams
Wound OD Min	2.57 in	6.53 cm
MLT	2.75 in	7.00 cm
A _t = Surface Area	17.42 in ²	112.4 cm ²
Permeability		60
μ 125		2.08 × L @ μ 60
μ 160		2.67 × L @ μ 60
μ 200		3.33 × L @ μ 60
μ 550		9.17 × L @ μ 60

9. Core Loss for Molypermalloy Powder Cores

Figure 23 depicts core loss curves for molypermalloy powder cores. These curves were obtained from Magnetics, and are typical curves for 60 μ to 200 μ .

Many catalogs state core loss in ohms per millihenry. Here it is expressed in milliwatts per gram.

10. Powder Core (Permeability Versus DC Bias)

Figure 24 shows inductance change versus DC bias for 60, 125 and 200 permeability materials.

In designing for operation at high DC currents, it is desirable to choose a core permeability which will result in maximum inductance at peak current.

Where:

$$H = \frac{NI}{\ell_m}$$

H = magnetizing force (ampturns/cm)

N = number of turns

I = peak currents (Amperes)

ℓ_m = mean magnetic path (cm)

Fig. 23. Core Loss Versus Frequency at 0.05T, 0.1T, and 0.5T
Typical Curves of 60, 125, 160, 200 μ

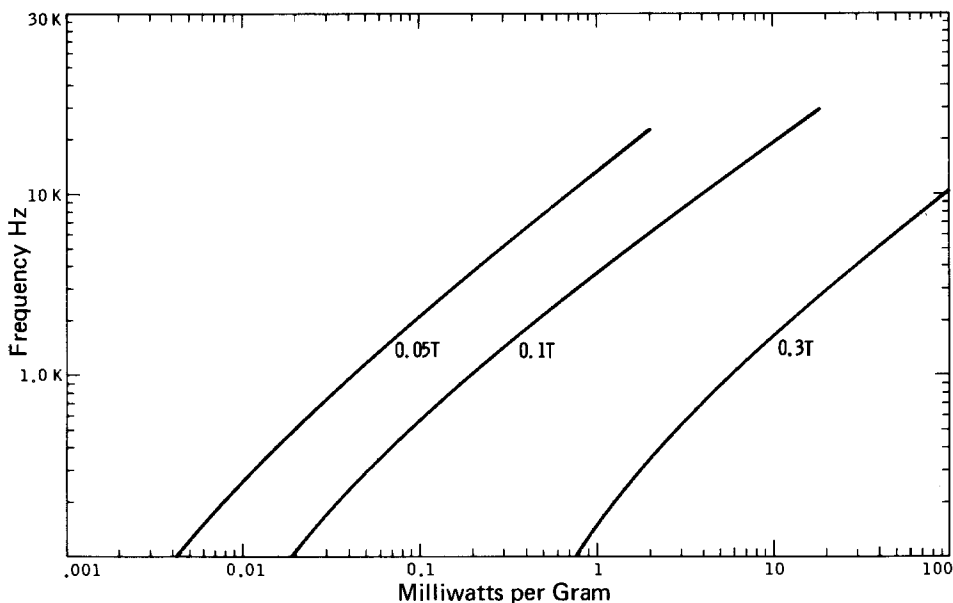
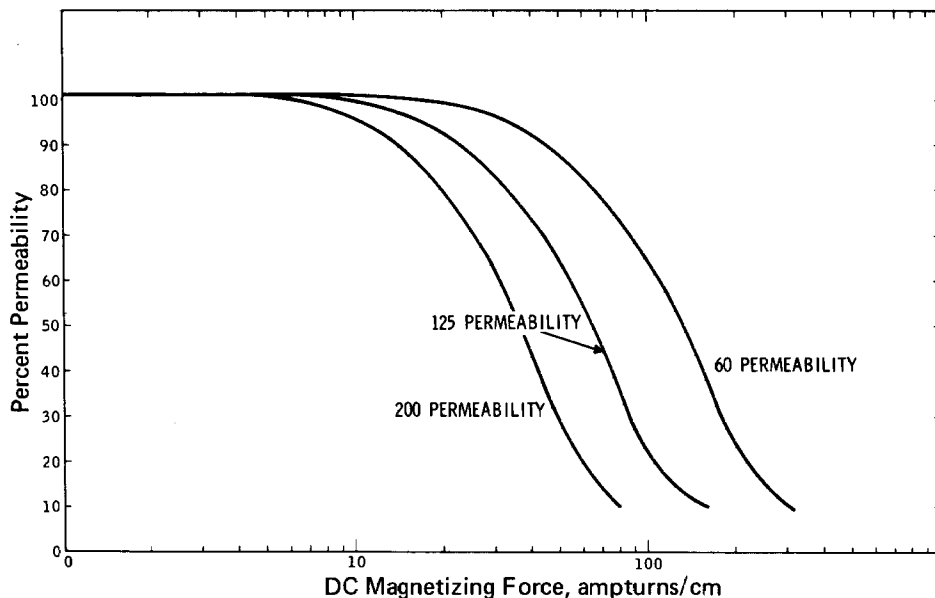

Fig. 24. Permeability vs. DC Bias

Permeability vs. DC Bias



11. Lamination, C Core, and Bobbin Magnetic and Dimensional Specifications

A. Definitions for Tables 16 through 41.

Tables 16 through 41 show magnetic and dimensional specifications for common EE and EI laminations, and C cores. The following information is provided in these tables:

- Manufacturer and part number
- Units
- Window area W_a divided by iron area A_c
- Window area W_a times the iron area A_c
- Iron area A_c
- Window area W_a
- Mean magnetic path length ℓ_m
- Core weight of silicon steel with unity stacking factor. For the appropriate weight multiply the solid weight by the stacking factor and density factor.

STACKING FACTOR

Thickness	Butt Jointed	Interleaved 1 x 1
0.004	0.90	0.80
0.006	0.90	0.85
0.014	0.95	0.90
0.018	0.95	0.90

DENSITY FACTOR

3% Silicon	7.64 gm/cc = 1.00
48% Nickel	8.25 gm/cc = 1.08
80% Nickel	8.74 gm/cc = 1.14

- Weight = copper fully wound
- MLT Fullwound = single winding on bobbin
- MLT 1st half = First of two windings wound with equal area.
- MLT 2nd half = Second of two windings wound with equal area.
- Transformer overall surface area A_t
- Dimensions: A, B, C, D, E, F for laminations; D, E, F, G for C Cores.
- Bobbin manufacturer and part number (Ref. 6)
- Bobbin inside winding length
- Bobbin inside build
- Bobbin winding area length X build
- Bracket manufacturer and part number, for C Cores (Ref. 7)

B. Nomographs for 11 Laminations and 15 C Cores

Figures 25 through 50 are nomographs for 11 different lamination sizes and 15 C core sizes. The nomographs display resistance, number of turns per bobbin, and wire size at a fill factor of $K_2 = 0.60$. These nomographs are included to provide a close approximation for breadboarding purposes.

Fig. 25. Nomograph for Lamination EE-30-31

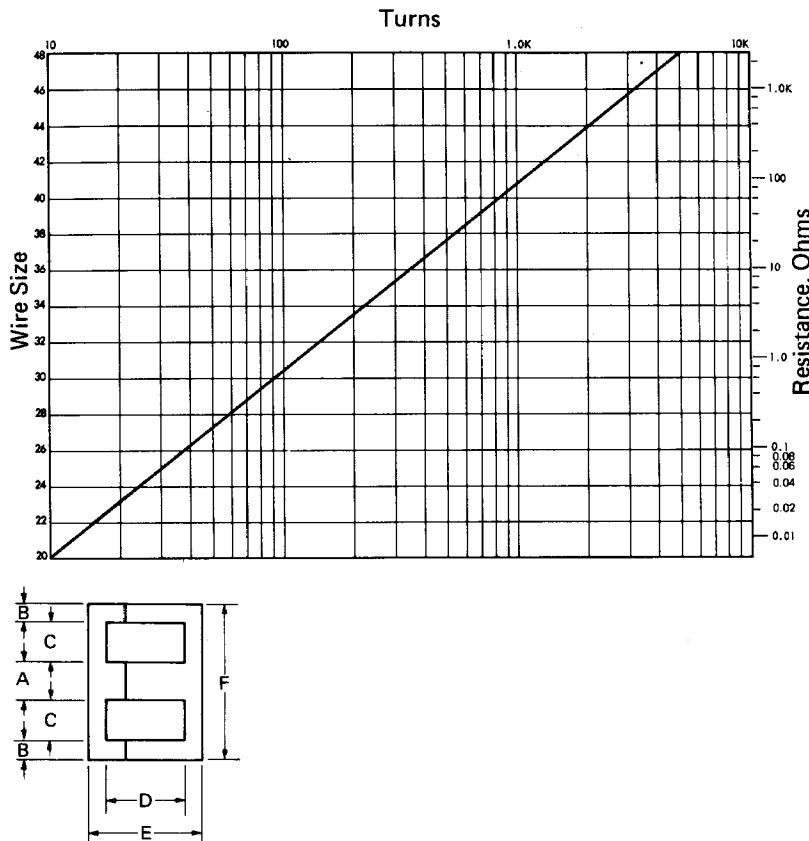

Table 16. Lamination Magnetics EE-30-31

	English	Metric
W_a/A_c	3.00	3.00
$W_a \times A_c$	0.000213 in ⁴	0.00964 cm ⁴
A_c	0.00879 in ²	0.0567 cm ²
W_a	0.0264 in ²	0.1701 cm ²
ℓ_m	0.938 in	2.381 cm
Core wt Solid	0.00224 lb	1.02 grams
Copper wt	0.002 lb	0.88 grams
MLT Fullwound	0.677 in	1.72 cm
MLT 1st Half	0.568 in	1.44 cm
MLT 2nd Half	0.785 in	1.99 cm
A_t	0.6374 in ²	4.11 cm ²
A	0.094 in	0.239 cm
B	0.047 in	0.119 cm
C	0.094 in	0.239 cm
D	0.281 in	0.714 cm
E	0.375 in	0.953 cm
F	0.375 in	0.953 cm
Bobbin Part No.	NY-GLASS #NY-1	
Bobbin Length	0.230 in	0.584 cm
Bobbin Build	0.069 in	0.175 cm
Bobbin Area	0.0159 in ²	0.102 cm ²

Fig. 26. Nomograph for Lamination EE-28-29

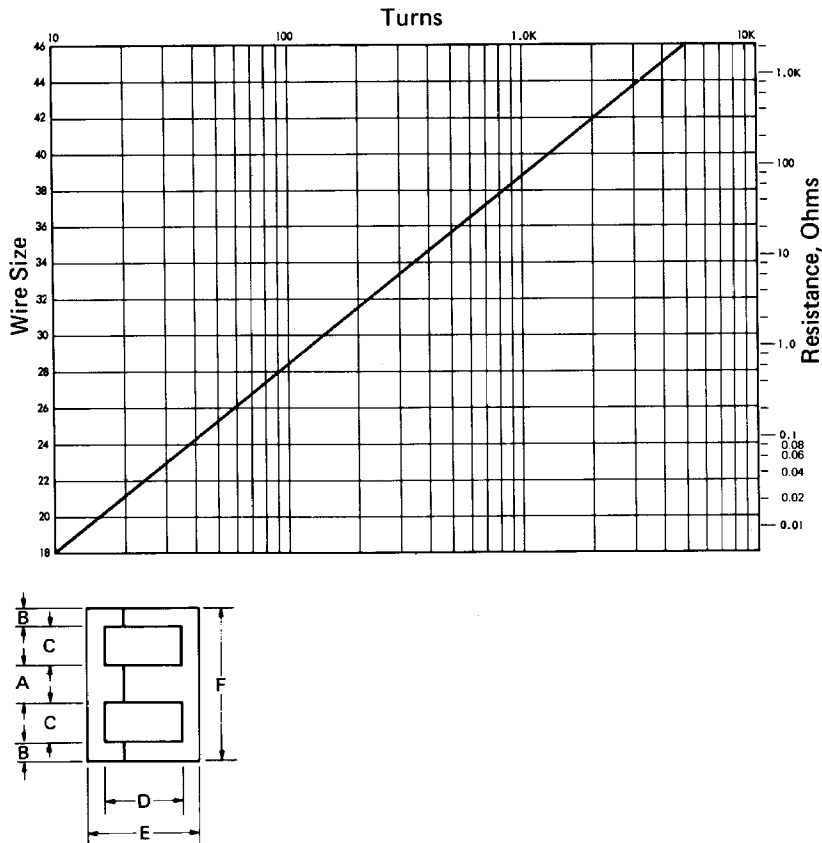

Table 17. Lamination Magnetics EE-28-29

	English	Metric
Wa/Ac	2.52	2.52
Wa × Ac	0.00061 in ⁴	0.0258 cm ⁴
Ac	0.0156 in ²	0.101 cm ²
Wa	0.0391 in ²	0.256 cm ²
ℓ _m	1.125 in	2.858 cm
Core wt Solid	0.00482 lb	2.19 grams
Copper wt	0.004 lb	1.85 grams
MLT Fullwound	0.892 in	2.265 cm
MLT 1st Half	0.740 in	1.879 cm
MLT 2nd Half	1.045 in	2.654 cm
A _t	1.027 in ²	6.625 cm ²
A	0.125 in	0.318 cm
B	0.062 in	0.157 cm
C	0.125 in	0.318 cm
D	0.312 in	0.792 cm
E	0.438 in	1.113 cm
F	0.500 in	1.270 cm
Bobbin Part No.	NY-GLASS #NY-2	
Bobbin Length	0.269 in	0.673 cm
Bobbin Build	0.097 in	0.246 cm
Bobbin Area	0.026 in ²	0.168 cm ²

Fig. 27. Nomograph for Lamination EI-187

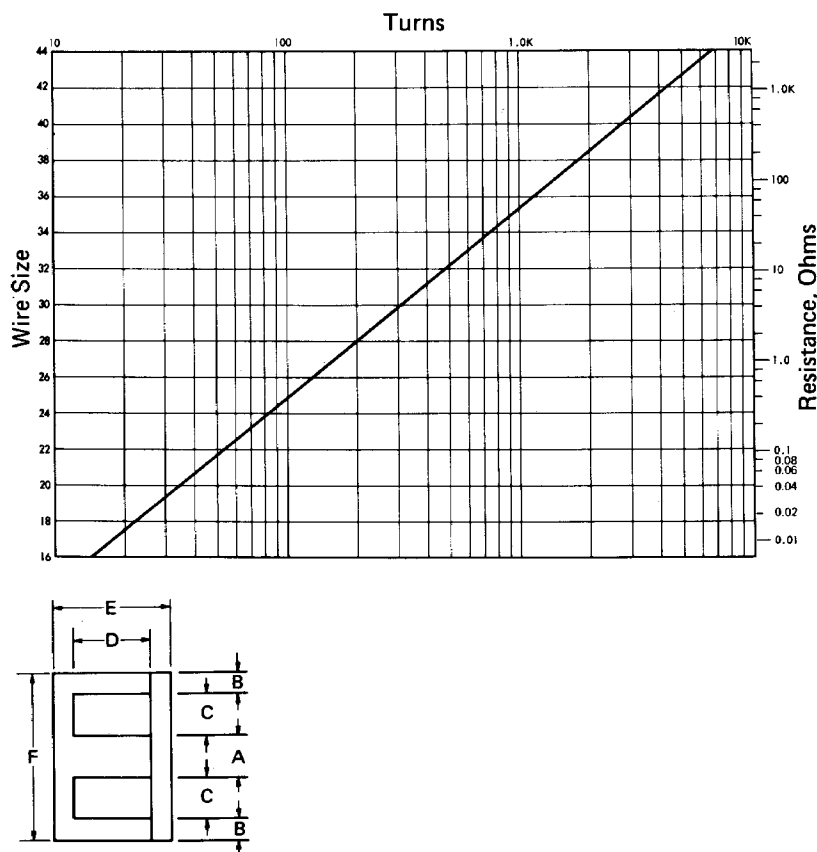

Table 18. Lamination Magnetics EI-187

	English	Metric
Wa/Ac	2.33	2.33
Wa × Ac	0.00288 in ⁴	0.120 cm ⁴
Ac	0.0352 in ²	0.227 cm ²
Wa	0.0820 in ²	0.529 cm ²
ℓ _m	1.625 in	4.128 cm
Core wt Solid	0.156 lb	7.09 grams
Copper wt	0.0136 lb	6.20 grams
MLT Fullwound	1.34 in	3.40 cm
MLT 1st Half	1.11 in	2.82 cm
MLT 2nd Half	1.57 in	3.99 cm
A _t	2.270 in ²	14.65 cm ²
A	0.188 in	0.478 cm
B	0.094 in	0.239 cm
C	0.188 in	0.478 cm
D	0.438 in	1.113 cm
E	0.625 in	1.588 cm
F	0.750 in	1.905 cm
Bobbin Part No.	NY-GLASS #NY-4	
Bobbin Length	0.375 in	0.953 cm
Bobbin Build	0.147 in	0.373 cm
Bobbin Area	0.0551 in ²	0.355 cm ²

Fig. 30. Nomograph for Lamination EI-375

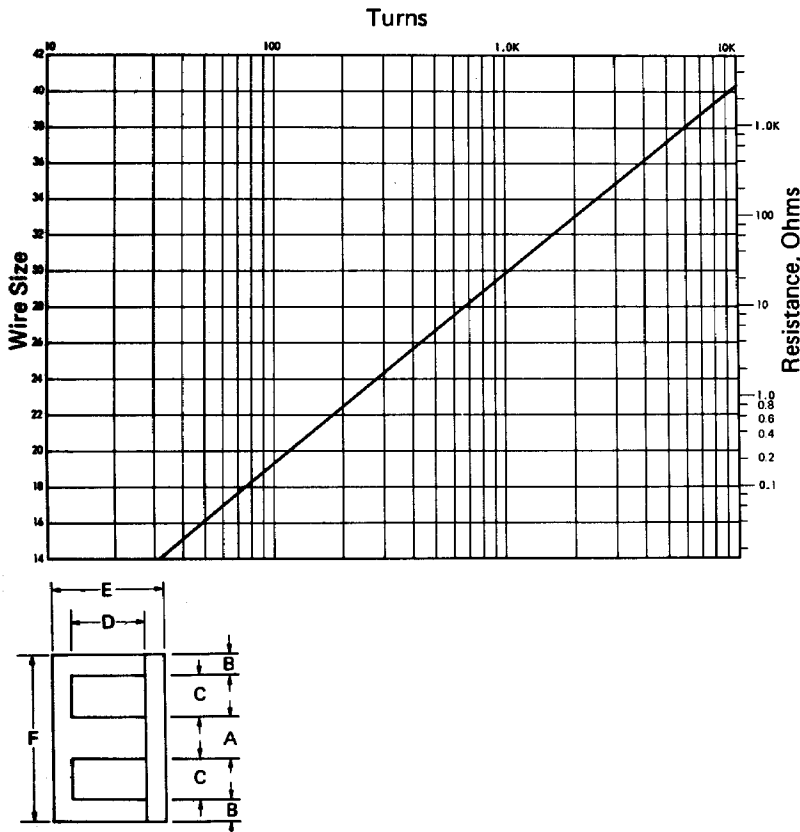

Table 21. Lamination Magnetics EI-375

	English	Metric
Wa/Ac	1.66	1.66
Wa × Ac	0.0327 in ⁴	1.374 cm ⁴
Ac	0.14 in ²	0.91 cm ²
Wa	0.234 in ²	1.51 cm ²
ℓ _m	2.88 in	7.30 cm
Core wt Solid	0.110 lb	49.7 grams
Copper wt	0.0772 lb	35.0 grams
MLT Fullwound	2.515 in	6.39 cm
MLT 1st Half	2.087 in	5.30 cm
MLT 2nd Half	2.94 in	7.47 cm
A _t	7.390 in ²	47.68 cm ²
A	0.375 in	0.953 cm
B	0.188 in	0.478 cm
C	0.312 in	0.792 cm
D	0.750 in	1.905 cm
E	1.125 in	2.858 cm
F	1.375 in	3.493 cm
Bobbin Part No.	NY-GLASS #NY-7	
Bobbin Length	0.665 in	1.689 cm
Bobbin Build	0.272 in	0.691 cm
Bobbin Area	1.181 in ²	1.1674 cm ²

Fig. 31. Nomograph for Lamination EI-50

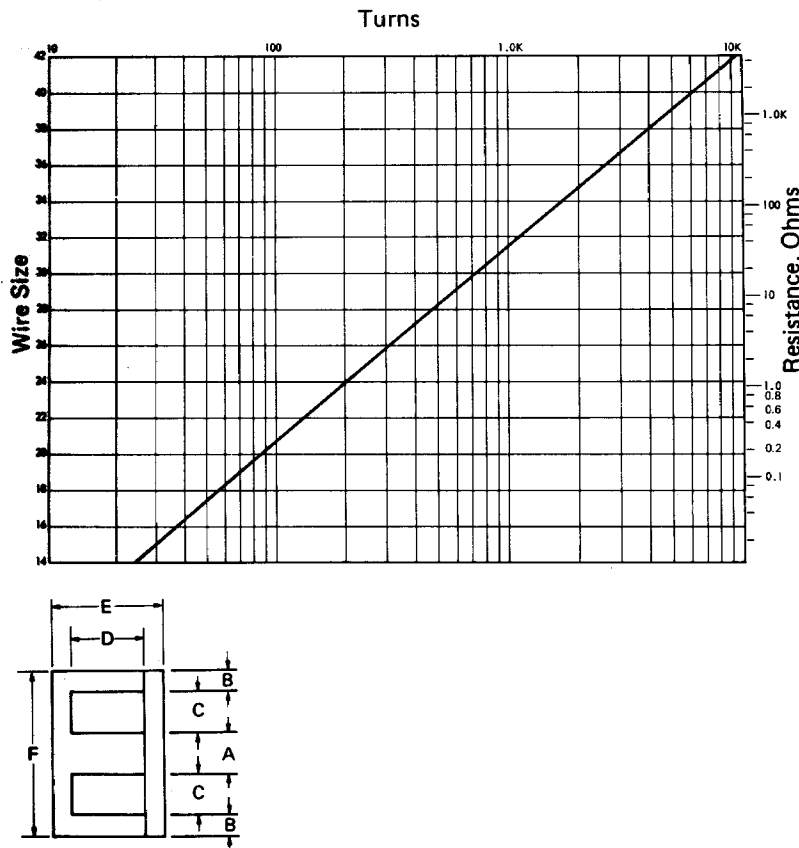

Table 22. Lamination Magnetics EI-50

	English	Metric
Wa/Ac	0.750	0.750
Wa × Ac	0.047 in ⁴	1.95 cm ⁴
Ac	0.250 in ²	1.61 cm ²
Wa	0.188 in ²	1.21 cm ²
ℓ _m	3.00 in	7.62 cm
Core wt Solid	0.203 lb	92.0 grams
Copper wt	0.0617 lb	28.0 grams
MLT Fullwound	2.82 in	7.15 cm
MLT 1st Half	2.50 in	6.36 cm
MLT 2nd Half	3.13 in	7.95 cm
A _t	8.93 in ²	57.6 cm ²
A	0.500 in	1.27 cm
B	0.250 in	0.635 cm
C	0.250 in	0.635 cm
D	0.750 in	1.91 cm
E	1.25 in	3.18 cm
F	1.50 in	3.81 cm
Bobbin Part No.	NY-GLASS #NY-44	
Bobbin Length	0.661 in	1.68 cm
Bobbin Build	0.200 in	0.508 cm
Bobbin Area	0.132 in ²	0.852 cm ²

Fig. 32. Nomograph for Lamination EI-21

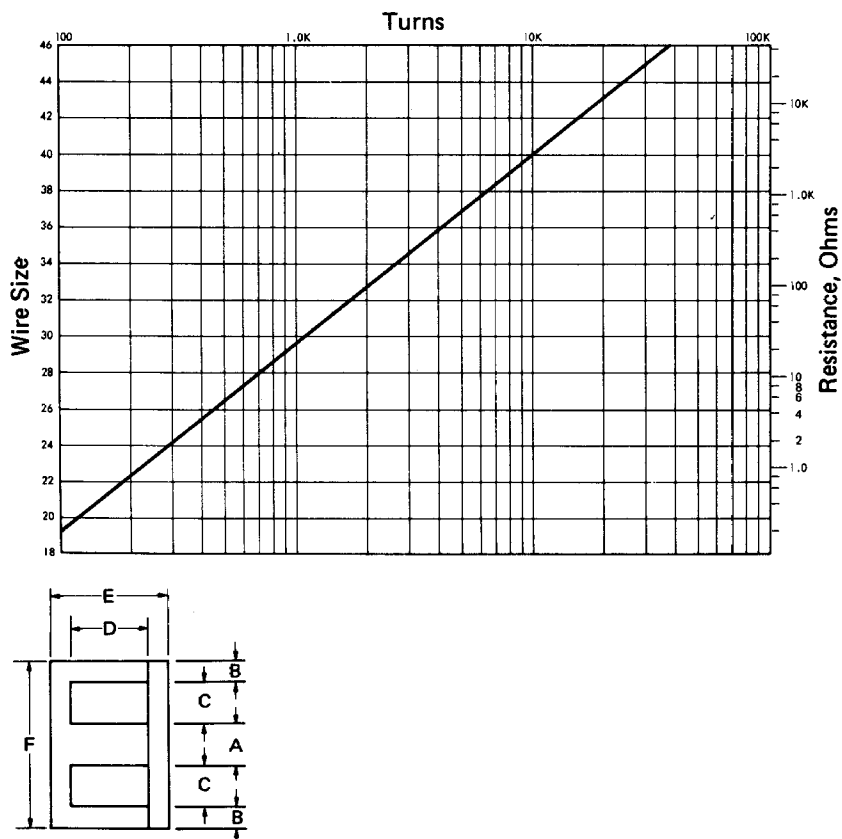

Table 23. Lamination Magnetics EI-21

	English	Metric
Wa/Ac	1.02	1.02
Wa × Ac	0.0635 in ⁴	2.64 cm ⁴
Ac	0.25 in ²	1.61 cm ²
Wa	0.254 in ²	1.64 cm ²
ℓ _m	3.25 in	8.255 cm
Core wt Solid	0.219 lb	99.3 grams
Copper wt	0.090 lb	41 grams
MLT Fullwound	3.01 in	7.92 cm
MLT 1st Half	2.60 in	6.59 cm
MLT 2nd Half	3.43 in	8.71 cm
A _t	10.2 in ²	66.0 cm ²
A	0.500 in	1.27 cm
B	0.250 in	0.635 cm
C	0.312 in	0.792 cm
D	0.812 in	2.06 cm
E	1.31 in	3.33 cm
F	1.63 in	4.13 cm
Bobbin Part No.	NY-GLASS #NY-9	
Bobbin Length	0.726 in	1.84 cm
Bobbin Build	0.265 in	0.673 cm
Bobbin Area	0.192 in ²	1.240 cm ²

Fig. 33. Nomograph for Lamination EI-625

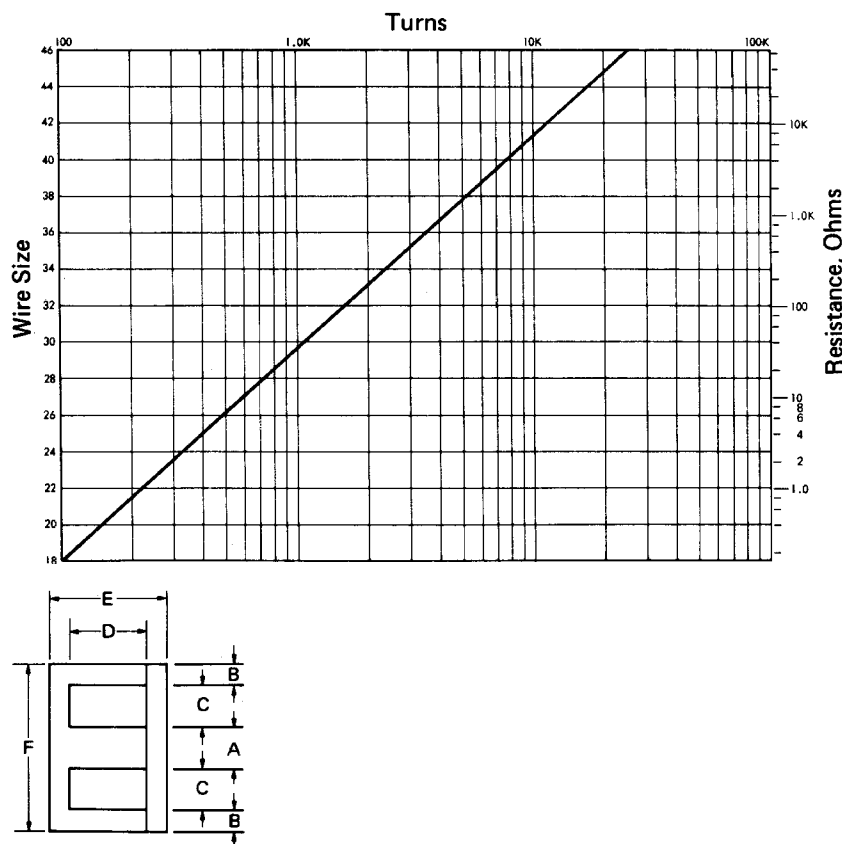

Table 24. Lamination Magnetics EI-625

	English	Metric
Wa/Ac	0.750	0.750
Wa × Ac	0.115 in ⁴	4.76 cm ⁴
Ac	0.391 in ²	2.52 cm ²
Wa	0.293 in ²	1.89 cm ²
ℓ _m	3.75 in	9.53 cm
Core wt Solid	0.395 lb	179 grams
Copper wt	0.154 lb	70 grams
MLT Fullwound	3.39 in	8.60 cm
MLT 1st Half	3.04 in	7.29 cm
MLT 2nd Half	3.73 in	9.48 cm
A _t	13.9 in ²	89.6 cm ²
A	0.625 in	1.59 cm
B	0.312 in	0.792 cm
C	0.312 in	0.792 cm
D	0.938 in	2.38 cm
E	1.56 in	3.97 cm
F	1.88 in	4.76 cm
Bobbin Part No.	NY-GLASS #NY-10	
Bobbin Length	0.841 in	2.14 cm
Bobbin Build	0.260 in	0.660 cm
Bobbin Area	0.218 in ²	1.41 cm ²

Fig. 34. Nomograph for Lamination EI-75

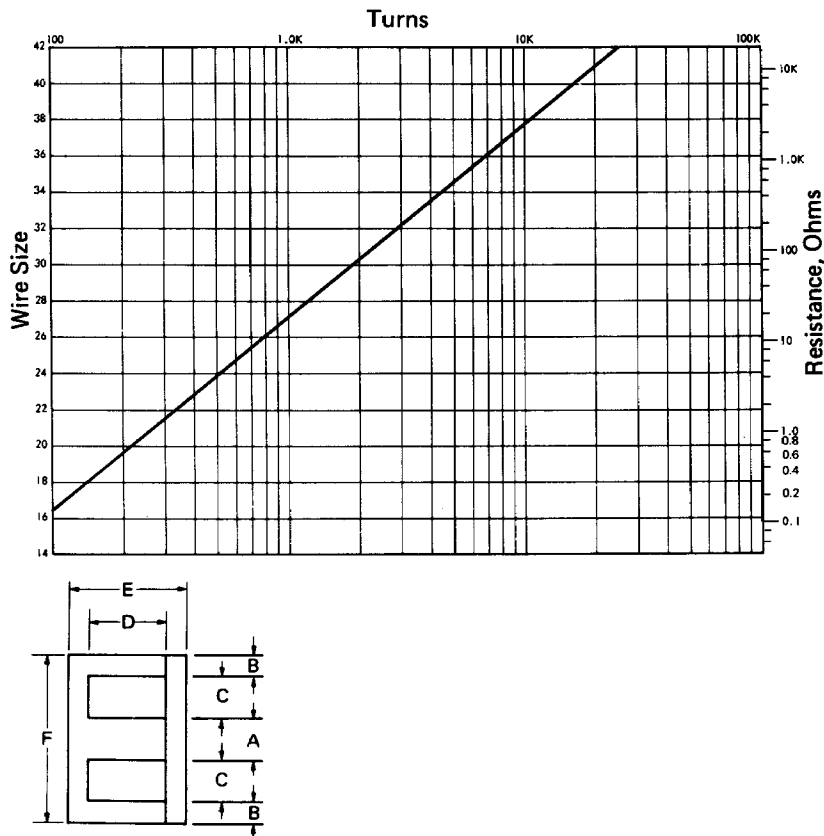

Table 25. Lamination Magnetics EI-75

	English	Metric
Wa/Ac	0.750	0.750
Wa × Ac	0.237 in ⁴	9.87 cm ⁴
Ac	0.563 in ²	3.63 cm ²
Wa	0.422 in ²	2.72 cm ²
ℓ _m	4.50 in	11.4 cm
Core wt Solid	0.688 lb	312 grams
Copper wt	0.232 lb	105 grams
MLT Fullwound	4.21 in	10.7 cm
MLT 1st Half	3.71 in	9.41 cm
MLT 2nd Half	4.72 in	12.0 cm
A _t	20.1 in ²	130 cm ²
A	0.750 in	1.91 cm
B	0.375 in	0.952 cm
C	0.375 in	0.952 cm
D	1.125 in	2.86 cm
E	1.875 in	4.76 cm
F	2.25 in	5.72 cm
Bobbin Part No.	NY-GLASS #NY-11	
Bobbin Length	1.02 in	2.59 cm
Bobbin Build	0.322 in	0.838 cm
Bobbin Area	0.330 in ²	2.13 cm ²

Fig. 35. Nomograph for Lamination EI-87

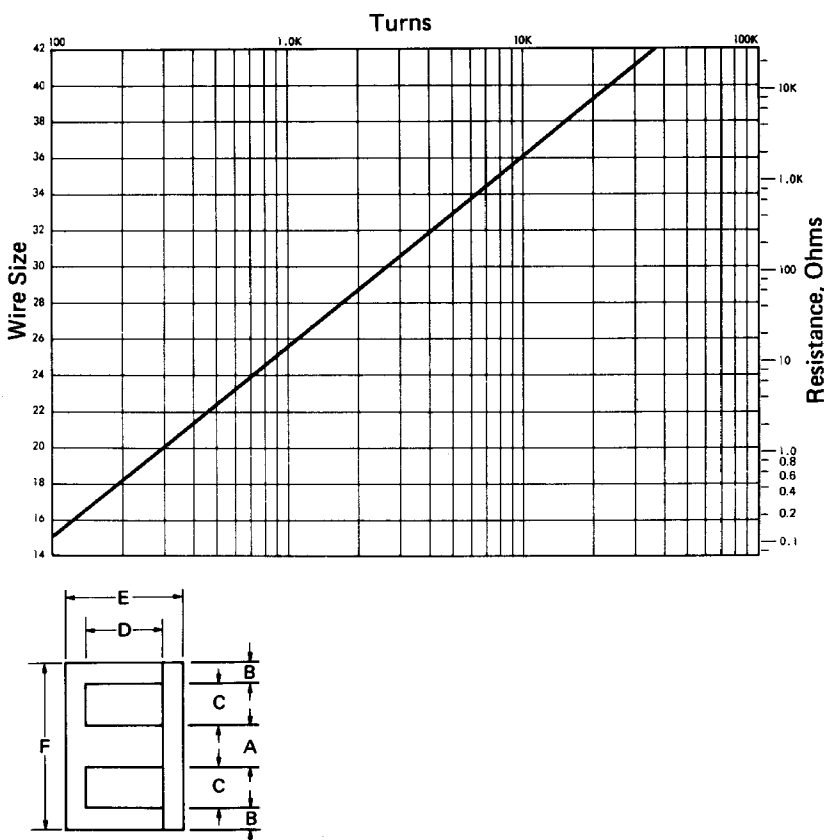

Table 26. Lamination Magnetics EI-87

	English	Metric
Wa/Ac	0.750	0.750
Wa × Ac	0.439 in ⁴	18.3 cm ⁴
Ac	0.766 in ²	4.94 cm ²
Wa	0.574 in ²	3.71 cm ²
ℓ _m	5.25 in	13.3 cm
Core wt Solid	1.06 lb	481 grams
Copper wt	0.375 lb	170 grams
MLT Fullwound	4.92 in	12.5 cm
MLT 1st Half	4.32 in	11.0 cm
MLT 2nd Half	5.52 in	14.0 cm
A _t	27.3 in ²	176 cm ²
A	0.875 in	2.22 cm
B	0.438 in	1.112 cm
C	0.438 in	1.112 cm
D	1.312 in	3.332 cm
E	2.188 in	5.557 cm
F	2.625 in	6.667 cm
Bobbin Part No.	NY-GLASS #NY-12	
Bobbin Length	1.21 in	3.073 cm
Bobbin Build	0.383 in	0.973 cm
Bobbin Area	0.464 in ²	2.993 cm ²

Fig. 36. Nomograph for C Core MC 0001

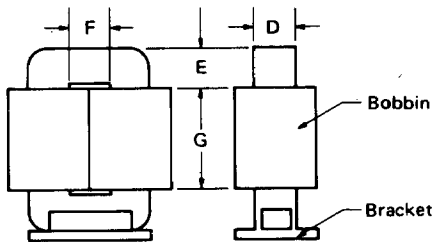
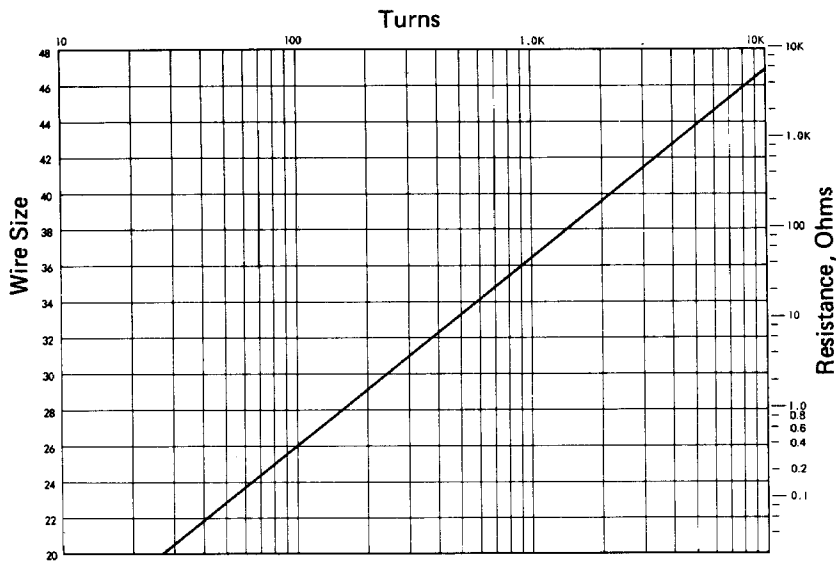

Table 27. C Core Magnetics MC 0001

	English	Metric
Wa/Ac		4.09
Wa X Ac	0.004 in ⁴	0.161 cm ⁴
Ac	0.031 in ²	0.20 cm ²
Wa	0.125 in ²	0.806 cm ²
ℓ _m	1.86 in	4.72 cm
Core wt Solid	0.016 lb	7.28 grams
Copper wt	0.015 lb	6.6 grams
MLT Fullwound	1.27 in	3.23 cm
MLT 1st Half	1.11 in	2.82 cm
MLT 2nd Half	1.43 in	3.63 cm
A _t	2.375 in ²	15.32 cm ²
D	0.25 in	0.635 cm
E	0.125 in	0.317 cm
F	0.25 in	0.635 cm
G	0.50 in	1.270 cm
Bobbin Part No.	Dorco Electronics # 12767	
Bobbin Length	0.43 in	1.092 cm
Bobbin Build	0.10 in	0.254 cm
Bobbin Area	0.043 in ²	0.277 cm ²
Bracket	Hallmark Metals # 04-008-02	

Fig. 37. Nomograph for C Core MC 0002

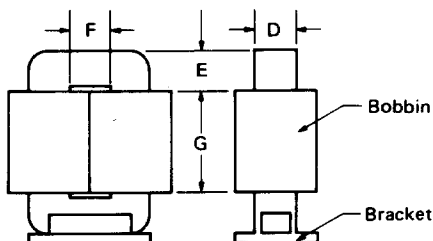
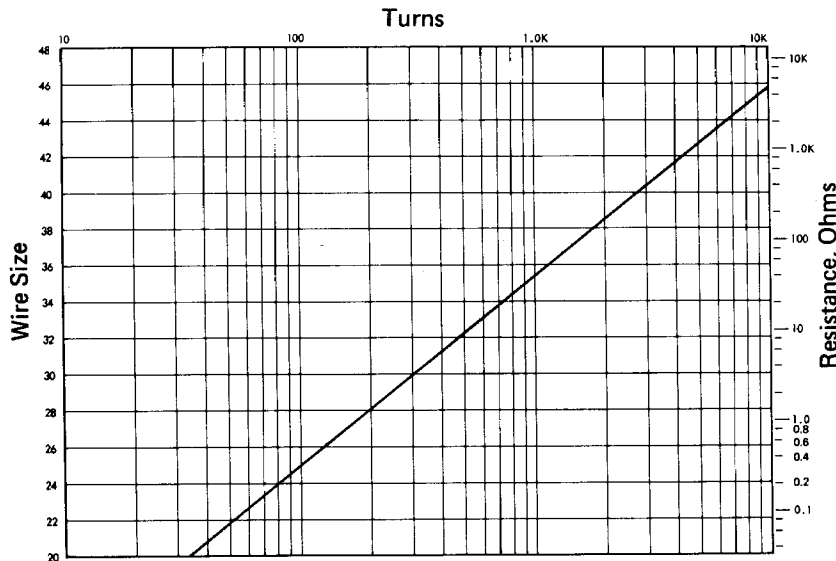

Table 28. C Core Magnetics MC 0002

	English	Metric
Wa/Ac		3.66
Wa X Ac	0.00733 in ⁴	0.305 cm ⁴
Ac	0.047 in ²	0.303 cm ²
Wa	0.156 in ²	1.006 cm ²
ℓ _m	2.293 in	5.82 cm
Core wt Solid	0.0296 lb	13.45 grams
Copper wt	0.0207 lb	9.4 grams
MLT Fullwound	1.39 in	3.53 cm
MLT 1st Half	1.24 in	3.15 cm
MLT 2nd Half	1.55 in	3.94 cm
A _t	3.25 in ²	20.96 cm ²
D	0.25 in	0.635 cm
E	0.187 in	0.476 cm
F	0.25 in	0.635 cm
G	0.625 in	1.588 cm
Bobbin Part No.	Dorco Electronics # 12768	
Bobbin Length	0.560 in	1.42 cm
Bobbin Build	0.100 in	0.254 cm
Bobbin Area	0.056 in ²	0.361 cm ²
Bracket	Hallmark Metals # 04-010-03	

Fig. 38. Nomograph for C Core MC 0004

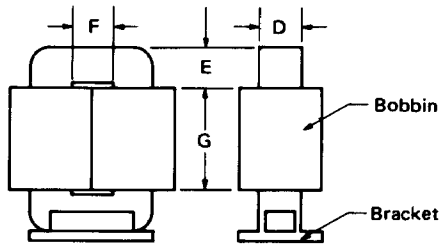
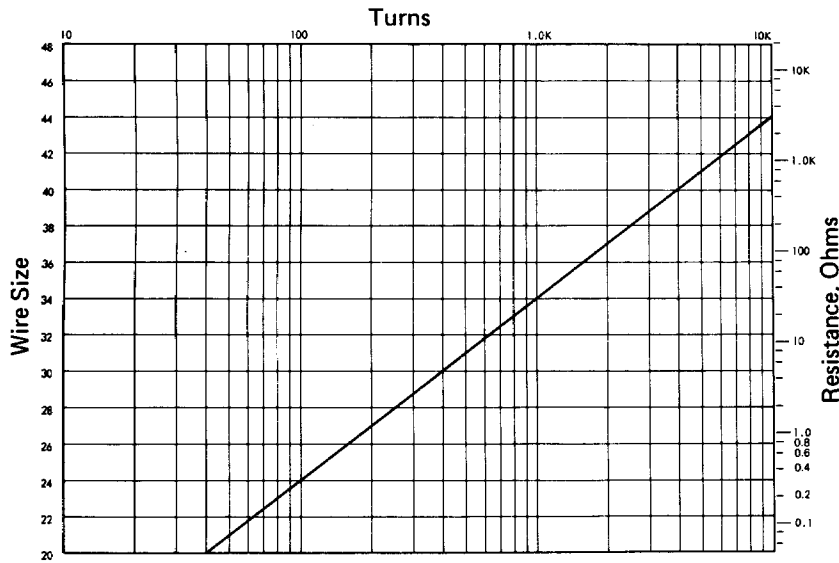

Table 29. C Core Magnetics MC 0004

	English	Metric
Wa/Ac		3.58
Wa × Ac	0.014 in ⁴	0.574 cm ⁴
Ac	0.063 in ²	0.406 cm ²
Wa	0.219 in ²	1.413 cm ²
ℓ _m	2.975 in	7.55 cm
Core wt Solid	0.0513 lb	22.27 grams
Copper wt	0.0282 lb	12.8 grams
MLT Fullwound	1.52 in	3.86 cm
MLT 1st Half	1.38 in	3.51 cm
MLT 2nd Half	1.65 in	4.19 cm
A _t	4.625 in ²	29.8 cm ²
D	0.25 in	0.635 cm
E	0.25 in	0.635 cm
F	0.25 in	0.635 cm
G	0.875 in	2.222 cm
Bobbin Part No.	Dorco Electronics # 12769	
Bobbin Length	0.800 in	2.032 cm
Bobbin Build	0.087 in	0.221 cm
Bobbin Area	0.0696 in ²	0.449 cm ²
Bracket	Hallmark Metals # 04-012-04	

Fig. 39. Nomograph for C Core MC 8400

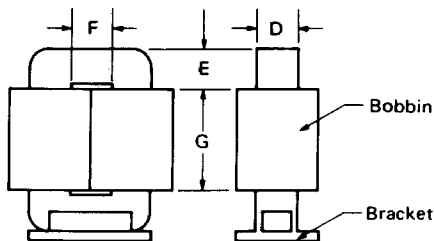
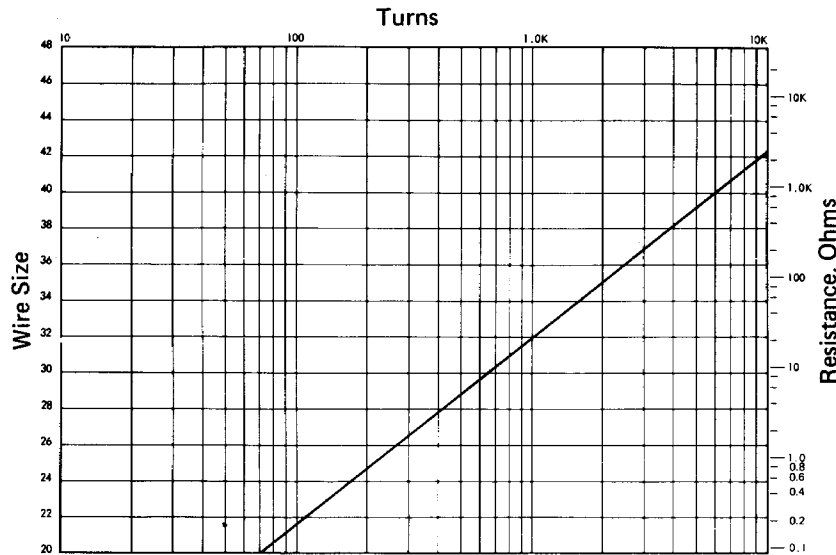

Table 30. C Core Magnetics MC 8400

	English	Metric
Wa/Ac		5.37
Wa × Ac	0.021 in ⁴	0.893 cm ⁴
Ac	0.062 in ²	0.403 cm ²
Wa	0.344 in ²	2.217 cm ²
ℓ _m	3.98 in	10.09 cm
Core wt Solid	0.0686 lb	31.14 grams
Copper wt	0.057 lb	26 grams
MLT Fullwound	1.52 in	3.86 cm
MLT 1st Half	1.38 in	3.51 cm
MLT 2nd Half	1.65 in	4.19 cm
A _t	6.125 in ²	39.5 cm ²
D	0.25 in	0.635 cm
E	0.25 in	0.635 cm
F	0.25 in	0.635 cm
G	1.375 in	3.493 cm
Bobbin Part No.	Dorco Electronics # 12770	
Bobbin Length	1.310 in	3.33 cm
Bobbin Build	0.087 in	0.221 cm
Bobbin Area	0.114 in ²	0.735 cm ²
Bracket	Hallmark Metals # 04-012-04	

Fig. 40. Nomograph for C Core MC 1200

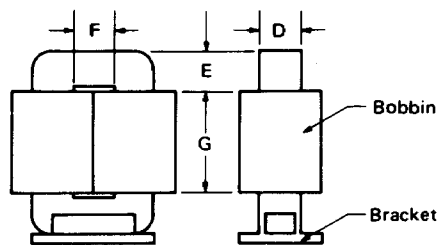
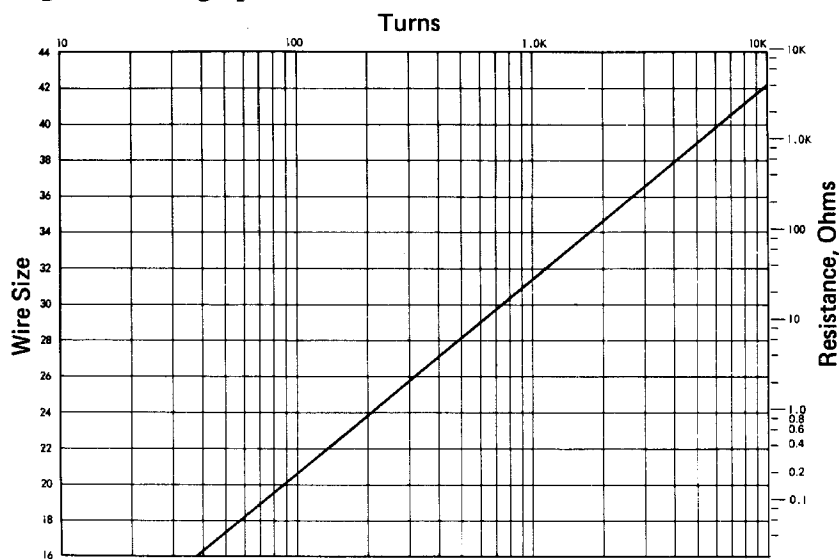

Table 31. C Core Magnetics MC 1200

	English	Metric
Wa/Ac		3.98
Wa × Ac	0.035 in ⁴	1.467 cm ⁴
Ac	0.094 in ²	0.606 cm ²
Wa	0.375 in ²	2.419 cm ²
ℓ _m	3.475 in	8.83 cm
Core wt Solid	0.090 lb	40.8 grams
Copper wt	0.088 lb	40 grams
MLT Fullwound	1.97 in	5.00 cm
MLT 1st Half	1.73 in	4.39 cm
MLT 2nd Half	2.21 in	5.61 cm
A _t	7.125 in ²	45.95 cm ²
D	0.375 in	0.953 cm
E	0.250 in	0.635 cm
F	0.375 in	0.953 cm
G	1.00 in	2.54 cm
Bobbin Part No.	Dorco Electronics # 12771	
Bobbin Length	0.920 in	2.34 cm
Bobbin Build	0.152 in	0.386 cm
Bobbin Area	0.140 in ²	0.902 cm ²
Bracket	Hallmark Metals # 06-014-04	

Fig. 41. Nomograph for C Core MC 4400

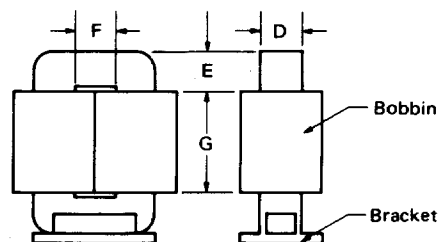
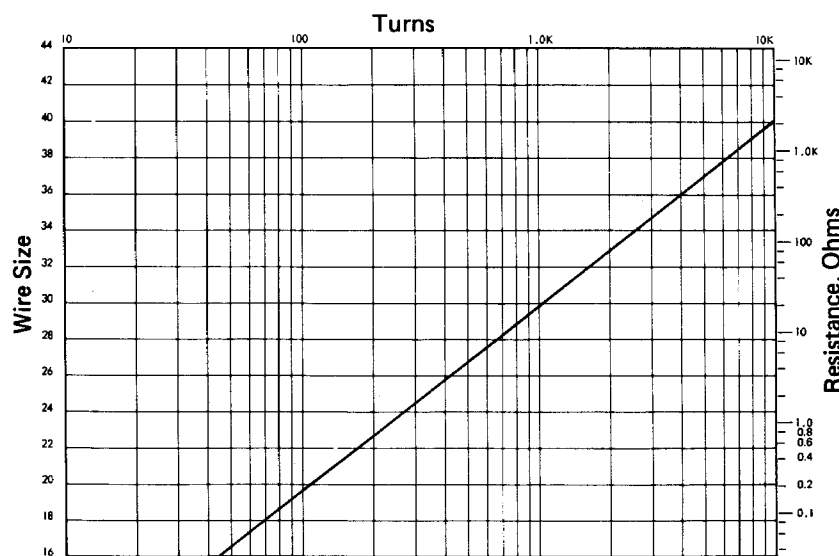

Table 32. C Core Magnetics MC 4400

	English	Metric
Wa/Ac		3.96
Wa × Ac	0.062 in ⁴	2.600 cm ⁴
Ac	0.125 in ²	0.806 cm ²
Wa	0.500 in ²	3.225 cm ²
ℓ _m	3.725 in	9.46 cm
Core wt Solid	0.128 lb	58.3 grams
Copper wt	0.14 lb	65 grams
MLT Fullwound	2.42 in	6.15 cm
MLT 1st Half	2.10 in	5.33 cm
MLT 2nd Half	2.74 in	6.96 cm
A _t	9.50 in ²	61.27 cm ²
D	0.50 in	1.27 cm
E	0.25 in	0.635 cm
F	0.50 in	1.27 cm
G	1.00 in	2.54 cm
Bobbin Part No.	Dorco Electronics # 12772	
Bobbin Length	0.910 in	2.31 cm
Bobbin Build	0.202 in	0.513 cm
Bobbin Area	0.184 in ²	1.186 cm ²
Bracket	Hallmark Metals # 08-100-04	

Fig. 42. Nomograph for C Core MC 2300

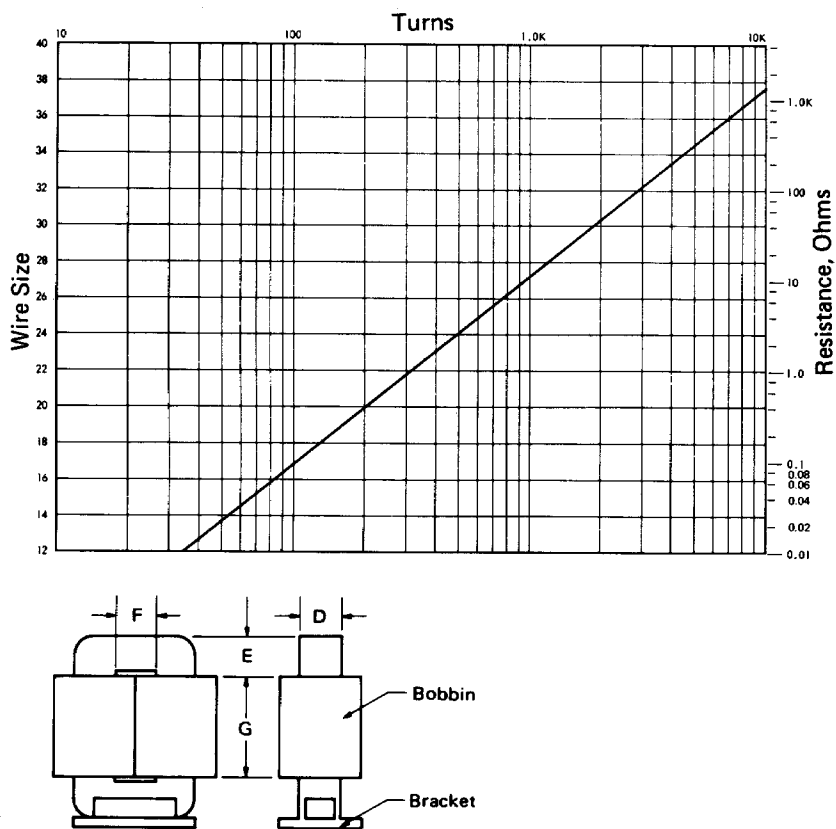

Table 33. C Core Magnetics MC 2300

	English	Metric
Wa/Ac		6.97
Wa X Ac	0.109 in ⁴	4.55 cm ⁴
Ac	0.125 in ²	0.806 cm ²
Wa	0.875 in ²	5.643 cm ²
ℓ _m	5.23 in	13.27 cm
Core wt Solid	0.180 lb	81.8 grams
Copper wt	0.255 lb	116 grams
MLT Fullwound	2.42 in	6.15 cm
MLT 1st Half	2.10 in	5.33 cm
MLT 2nd Half	2.74 in	6.96 cm
A _t	13.25 in ²	85.46 cm ²
D	0.50 in	1.27 cm
E	0.25 in	0.635 cm
F	0.50 in	1.27 cm
G	1.75 in	4.45 cm
Bobbin Part No.	Dorco Electronics # 12773	
Bobbin Length	1.660 in	4.22 cm
Bobbin Build	0.202 in	0.513 cm
Bobbin Area	0.335 in ²	2.16 cm ²
Bracket	Hallmark Metals # 08-100-04	

Fig. 43. Nomograph for C Core MC 1300

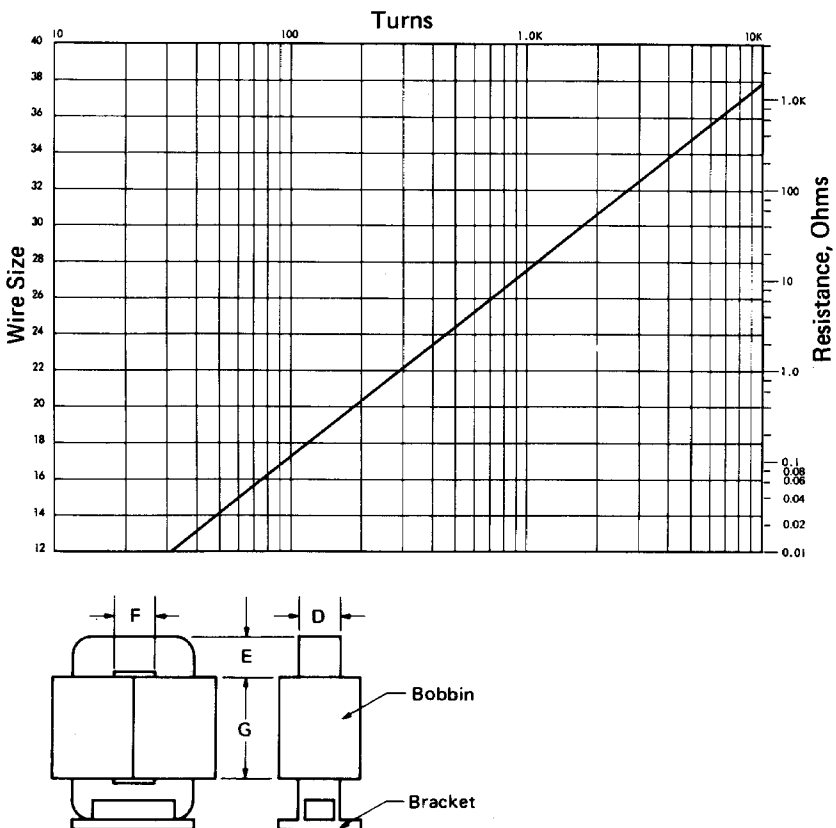

Table 34. C Core Magnetics MC 1300

	English	Metric
Wa/Ac		4.15
Wa X Ac	0.146 in ⁴	6.1 cm ⁴
Ac	0.187 in ²	1.21 cm ²
Wa	0.781 in ²	5.04 cm ²
ℓ _m	5.57 in	14.16 cm
Core wt Solid	0.288 lb	130 grams
Copper wt	0.242 lb	110 grams
MLT Fullwound	2.67 in	6.78 cm
MLT 1st Half	2.35 in	5.97 cm
MLT 2nd Half	2.99 in	7.59 cm
A _t	16.23 in ²	104.7 cm ²
D	0.375 in	0.952 cm
E	0.50 in	1.27 cm
F	0.50 in	1.27 cm
G	1.562 in	3.97 cm
Bobbin Part No.	Dorco Electronics # 12774	
Bobbin Length	1.470 in	3.73 cm
Bobbin Build	0.202 in	0.513 cm
Bobbin Area	0.297 in ²	1.915 cm ²
Bracket	Hallmark Metals # 06-108-08	

Fig. 44. Nomograph for C Core MC 0014

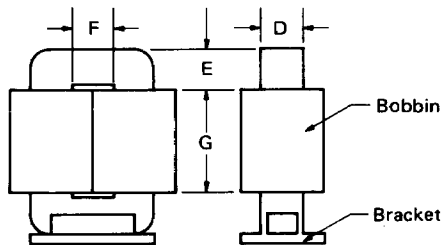
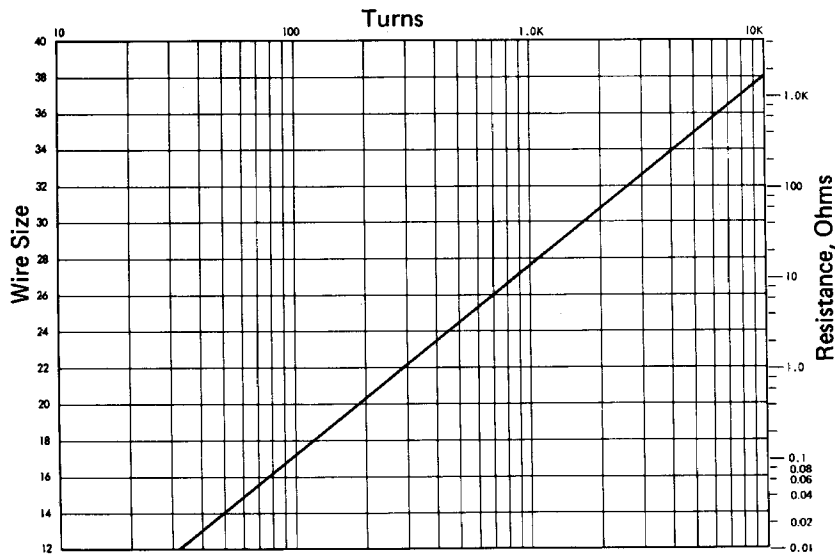

Table 35. C Core Magnetics MC 0014

	English	Metric
Wa/Ac		3.12
Wa X Ac	0.195 in ⁴	8.11 cm ⁴
Ac	0.250 in ²	1.61 cm ²
Wa	0.781 in ²	5.04 cm ²
ℓ _m	5.574 in	14.2 cm
Core wt Solid	0.384 lb	174.0 grams
Copper wt	0.264 lb	120 grams
MLT Fullwound	2.92 in	7.42 cm
MLT 1st Half	2.60 in	6.60 cm
MLT 2nd Half	3.24 in	8.23 cm
A _t	17.37 in ²	112.0 cm ²
D	0.50 in	1.27 cm
E	0.50 in	1.27 cm
F	0.50 in	1.27 cm
G	1.562 in	3.97 cm
Bobbin Part No.	Dorco Electronics # 12775	
Bobbin Length	1.470 in	3.73 cm
Bobbin Build	0.202 in	0.513 cm
Bobbin Area	0.297 in ²	1.915 cm ²
Bracket	Hallmark Metals # 08-108-08	

Fig. 45. Nomograph for C Core MC 1030

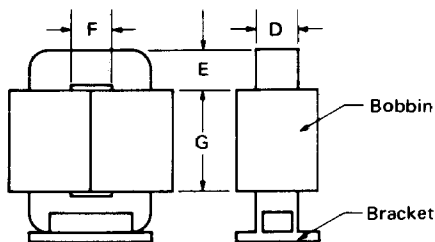
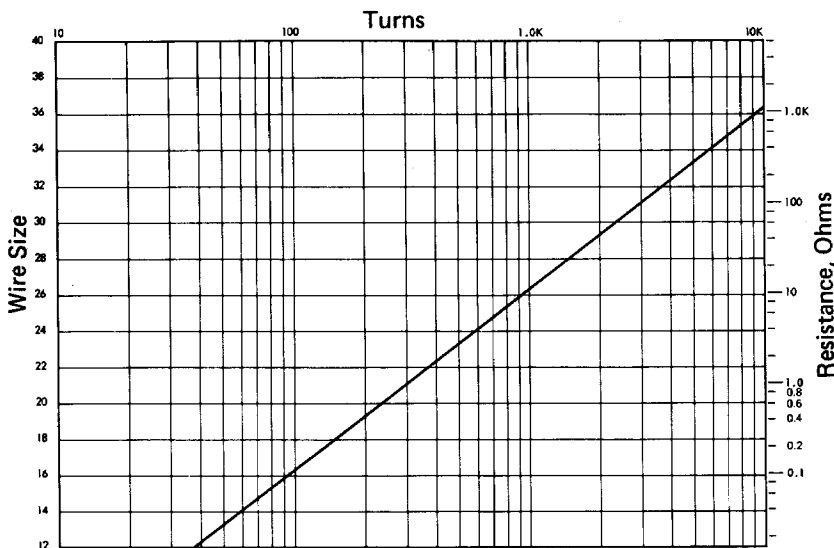

Table 36. C Core Magnetics MC 1030

	English	Metric
Wa/Ac		3.28
Wa X Ac	0.26 in ⁴	10.93 cm ⁴
Ac	0.281 in ²	1.81 cm ²
Wa	0.937 in ²	6.04 cm ²
ℓ _m	5.34 in	13.5 cm
Core wt Solid	0.415 lb	188 grams
Copper wt	0.434 lb	197 grams
MLT Fullwound	3.39 in	8.61 cm
MLT 1st Half	2.98 in	7.57 cm
MLT 2nd Half	3.80 in	9.65 cm
A _t	18.81 in ²	121.3 cm ²
D	0.750 in	1.905 cm
E	0.375 in	0.952 cm
F	0.625 in	1.587 cm
G	1.500 in	3.81 cm
Bobbin Part No.	Dorco Electronics # 12776	
Bobbin Length	1.470 in	3.73 cm
Bobbin Build	0.260 in	0.660 cm
Bobbin Area	0.382 in ²	2.46 cm ²
Bracket	Hallmark Metals # 012-106-06	

Fig. 46. Nomograph for C Core MC 1000

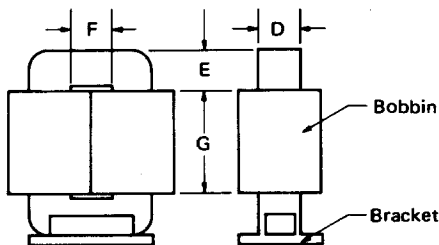
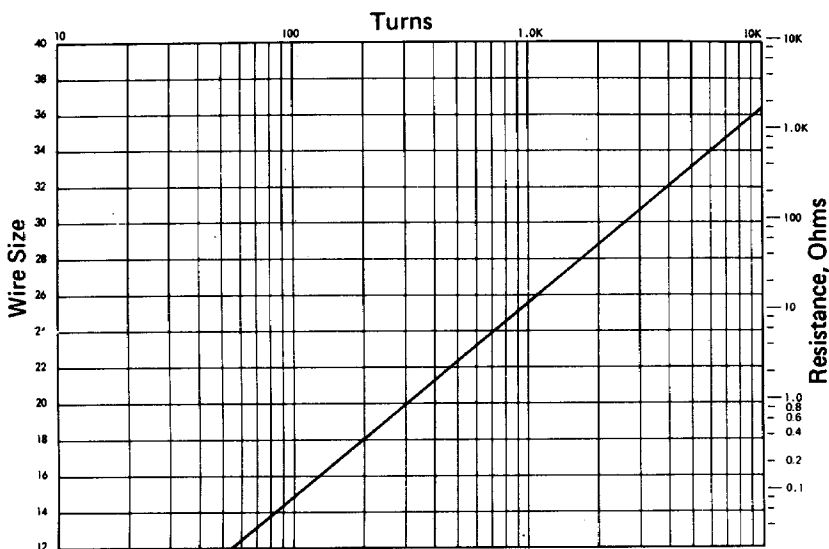

Table 37. C Core Magnetics MC 1000

	English	Metric
Wa/Ac		3.11
Wa X Ac	0.474 in ⁴	19.68 cm ⁴
Ac	0.3906 in ²	2.517 cm ²
Wa	1.210 in ²	7.82 cm ²
ℓ _m	6.25 in	15.9 cm
Core wt Solid	0.674 lb	306 grams
Copper wt	0.414 lb	188 grams
MLT Fullwound	3.99 in	10.13 cm
MLT 1st Half	3.59 in	9.12 cm
MLT 2nd Half	4.39 in	11.15 cm
A _t	24.52 in ²	158.2 cm ²
D	1.00 in	2.54 cm
E	0.3906 in	0.991 cm
F	0.625 in	1.59 cm
G	1.937 in	4.92 cm
Bobbin Part No.	Dorco Electronics # 12777	
Bobbin Length	1.846 in	4.68 cm
Bobbin Build	0.255 in	0.647 cm
Bobbin Area	0.470 in ²	3.04 cm ²
Bracket	Hallmark Metals # 10-107-06	

Fig. 47. Nomograph for C Core MC 1610

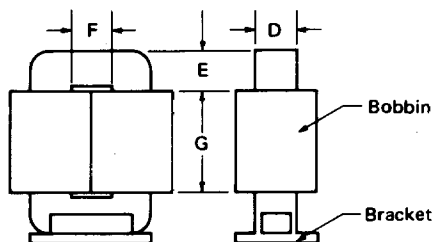
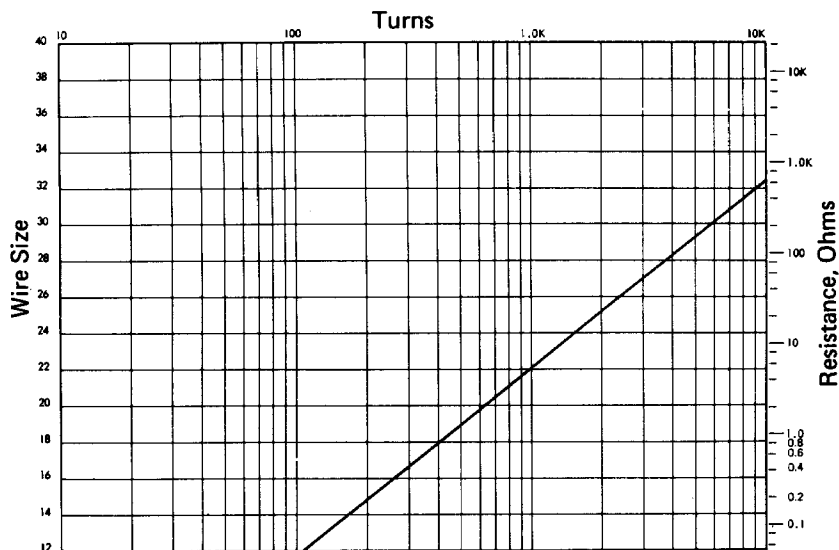

Table 38. C Core Magnetics MC 1610

	English	Metric
Wa/Ac		9.0
Wa X Ac	0.563 in ⁴	23.39 cm ⁴
Ac	0.250 in ²	1.61 cm ²
Wa	2.250 in ²	14.51 cm ²
ℓ _m	7.46 in	18.95 cm
Core wt Solid	0.515 lb	233 grams
Copper wt	1.38 lb	626 grams
MLT Fullwound	4.48 in	11.38 cm
MLT 1st Half	3.38 in	8.58 cm
MLT 2nd Half	5.58 in	14.17 cm
A _t	40 in ²	258 cm ²
D	0.50 in	1.27 cm
E	0.50 in	1.27 cm
F	1.50 in	3.81 cm
G	1.50 in	3.81 cm
Bobbin Part No.	Dorco Electronics # 12778	
Bobbin Length	1.41 in	3.58 cm
Bobbin Build	0.70 in	1.78 cm
Bobbin Area	0.987 in ²	6.37 cm ²
Bracket	Hallmark Metals # 08-208-08	

Fig. 48. Nomograph for C Core MC 2000

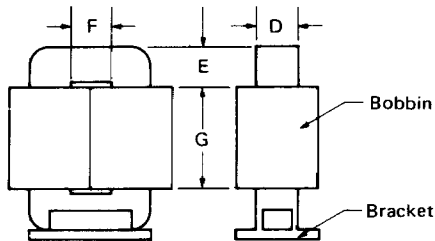
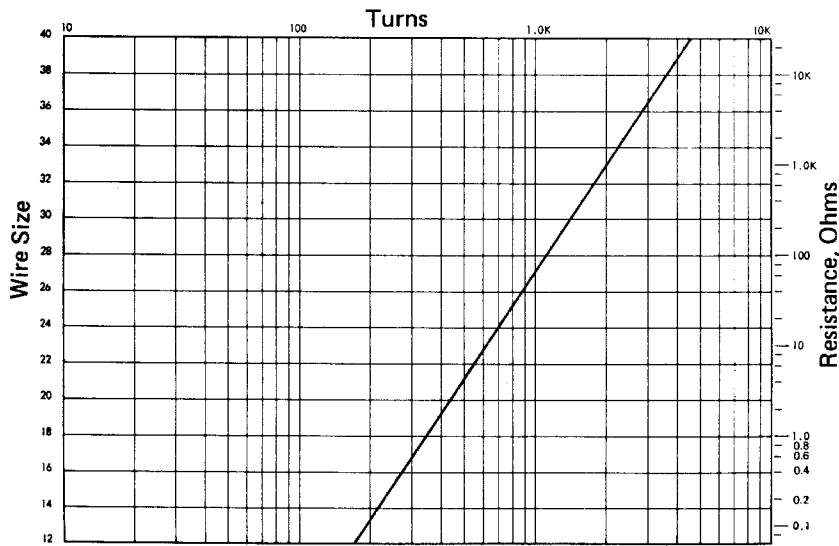

Table 39. C Core Magnetics MC 2000

	English	Metric
Wa/Ac		6.22
Wa X Ac	0.947 in ⁴	39.36 cm ⁴
Ac	0.3906 in ²	2.52 cm ²
Wa	2.42 in ²	15.62 cm ²
ℓ _m	7.5 in	19.07 cm
Core wt Solid	0.808 lb	366 grams
Copper wt	1.64 lb	744 grams
MLT Fullwound	5.02 in	12.75 cm
MLT 1st Half	4.11 in	10.44 cm
MLT 2nd Half	5.91 in	15.01 cm
A _t	40.9 in ²	264 cm ²
D	1.00 in	2.54 cm
E	0.3906 in	0.992 cm
F	1.25 in	3.175 cm
G	1.937 in	4.92 cm
Bobbin Part No.	Dorco Electronics # 12779	
Bobbin Length	1.845 in	4.69 cm
Bobbin Build	0.575 in	1.46 cm
Bobbin Area	1.061 in ²	6.84 cm ²
Bracket	Hallmark Metals # 10-202-07	

Fig. 49. Nomograph for C Core MC 6800

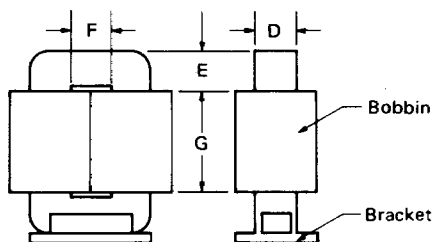
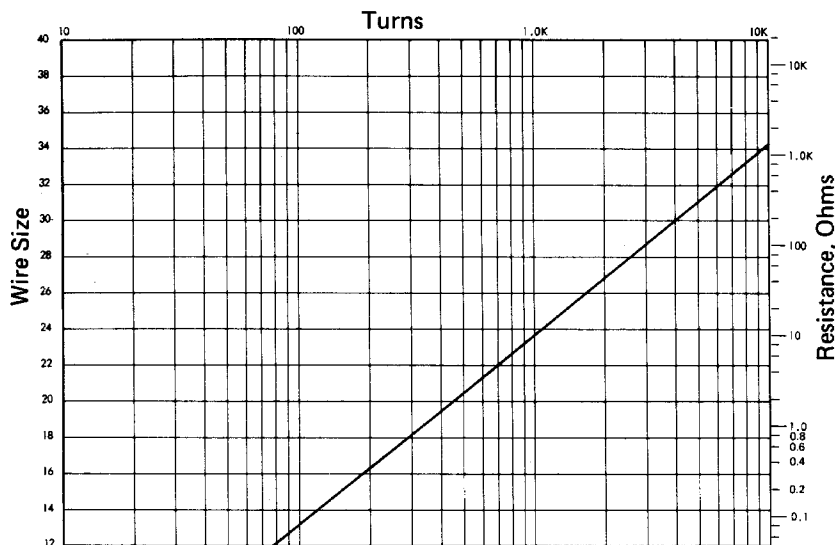

Table 40. C Core Magnetics MC 6800

	English	Metric
Wa/Ac		3.08
Wa X Ac	0.976 in ⁴	40.65 cm ⁴
Ac	0.563 in ²	3.63 cm ²
Wa	1.734 in ²	11.20 cm ²
ℓ _m	7.21 in	18.31 cm
Core wt Solid	1.105 lb	501 grams
Copper wt	1.25 lb	568 grams
MLT Fullwound	5.18 in	13.16 cm
MLT 1st Half	4.68 in	11.88 cm
MLT 2nd Half	5.69 in	14.45 cm
A _t	35.43 in ²	228.5 cm ²
D	1.50 in	3.81 cm
E	0.375 in	0.952 cm
F	0.750 in	1.905 cm
G	2.312 in	5.873 cm
Bobbin Part No.	Dorco Electronics # 12780	
Bobbin Length	2.222 in	5.64 cm
Bobbin Build	0.322 in	0.818 cm
Bobbin Area	0.715 in ²	4.61 cm ²
Bracket	Hallmark Metals # 18-108-06	

Fig. 50. Nomograph for C Core MC 1620

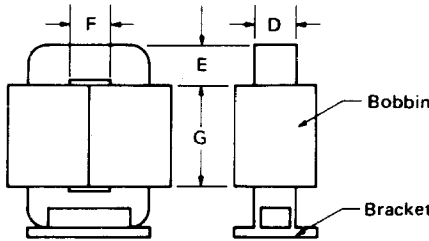
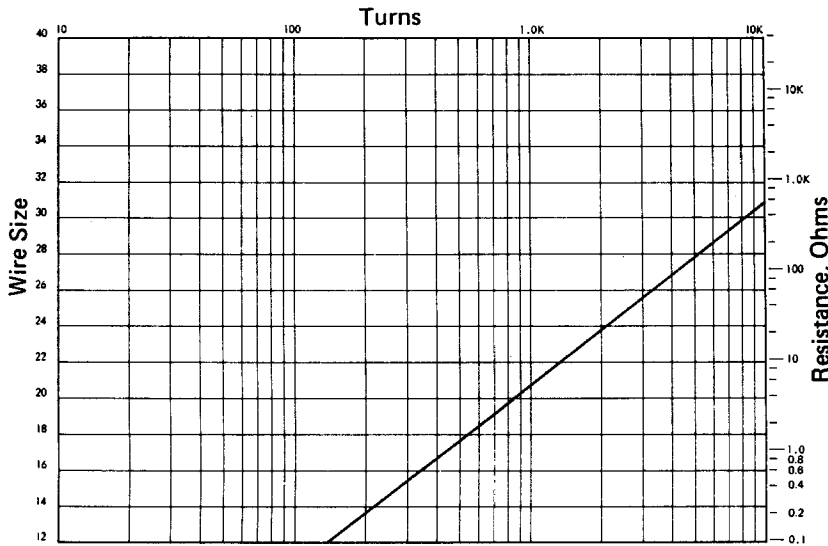

Table 41. C Core Magnetics MC 1620

	English	Metric
Wa/Ac		5.44
Wa X Ac	1.72 in ⁴	71.73 cm ⁴
Ac	0.562 in ²	3.625 cm ²
Wa	3.063 in ²	19.76 cm ²
ℓ _m	9.175 in	23.3 cm
Core wt Solid	1.42 lb	646 grams
Copper wt	2.47 lb	1120 grams
MLT Fullwound	5.9 in	14.99 cm
MLT 1st Half	4.61 in	11.71 cm
MLT 2nd Half	7.19 in	18.26 cm
A _t	63.25 in ²	408 cm ²
D	0.750 in	1.905 cm
E	0.750 in	1.905 cm
F	1.750 in	4.45 cm
G	1.750 in	4.45 cm
Bobbin Part No.	Dorco Electronics # 12781	
Bobbin Length	1.630 in	4.14 cm
Bobbin Build	0.820 in	2.08 cm
Bobbin Area	1.34 in ²	8.62 cm ²
Bracket	Hallmark Metals # 012-304-012	

12. Temperature Rise Versus Surface Area Dissipation due to Power Loss

Power loss (core loss + winding loss) in a transformer produces a temperature rise which must be controlled to prevent damage or failure. Heat is dissipated from the transformer surfaces by a combination of radiation and convection and is dependent upon total exposed surface area. Dissipation is expressed in watts per square centimeter of surface area.

Temperature rise in a transformer winding cannot be predicted with complete precision. Many different techniques are used.

A method for temperature rise computation used by transformer designers is reasonably accurate for open core and coil construction. It is based on the assumptions that core and coil losses are lumped together, and that this energy is dissipated through the circumferential area of the coil and core.

The nomograph of Fig. 51 (data obtained from Ref. 4) shows temperature rise versus power loss (core loss + copper loss), expressed in watts per square centimeter of surface area, with heat transfer by combined radiation and convection.

The nomograph is based on heat transfer from a vertical surface by 45 percent convection and 55 percent radiation, with an emissivity of 0.95 in a 25°C room at sea level. The heat loss from the upper side of a flat horizontal surface by convection is approxi-

mately 15 to 20 percent more than from the vertical surface. On the under side, the heat loss depends on the area and conductivity of the surface.

Fig. 51. Temperature Rise Versus Surface Dissipation

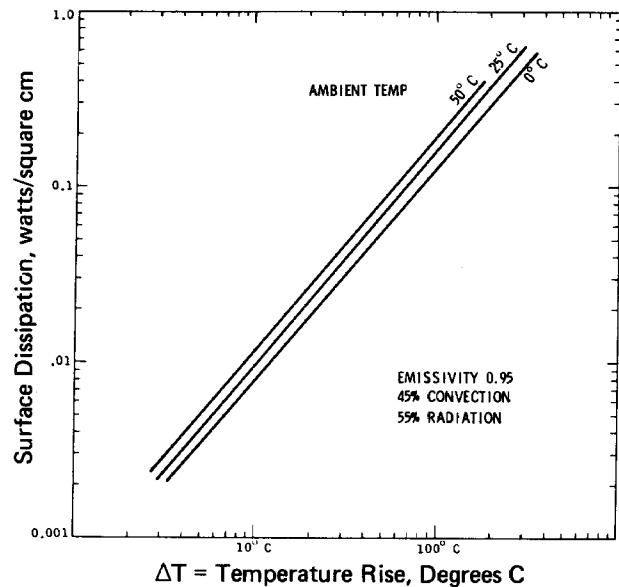

13. Maximum Permissible Current Density for 50°C Rise

Figures 52, 53, and 54

The curves shown are based upon a maximum permissible temperature rise of 50°C, with surface dissipation of 0.07 watts/cm². Maximum efficiency is achieved when the iron power loss and the copper power loss are equal. The data are based upon an assumption of 50% iron and 50% copper power losses. Surface areas for toroidal cores, laminations, and C cores have been calculated. Power dissipated as heat in the transformer is:

$$A_t (\text{cm}^2) \times 0.07 \text{ Watts/cm}^2 = W_T$$

	Where:
$W_c = W_I = W_T/2$	$W_c =$ Copper Loss
$W_a (\text{cm}^2) \times N/\text{cm}^2 = N$	$W_I =$ Iron Loss
$R = N \times \Omega/\text{cm} \times \text{MLT}$	$W_T =$ Total Loss
$W_c = I^2 R$	$N =$ Number of turns (for a given wire size.)
$I = \sqrt{W_c/R}$	$N/\text{cm}^2 =$ Table 2 (K) for a given wire size.
	$W_a =$ Window Area

$$\text{Current Density } I/\text{cm}^2 = I/\text{Wire Area (cm}^2)$$

These current densities are useful in picking out a first choice of wire size for a given current requirement, but should not be regarded as final. Instead, the regulation, or other performance criteria should govern the final choice of wire size.

The surface areas A_t for the toroids, laminations, and C cores were computed from Figures 55, 56 and 57. Designations for terms are taken from tables of toroids, laminations, and C cores in this text.

Fig. 52. Current Density vs. Surface Area for a 50° C Rise (Laminations)

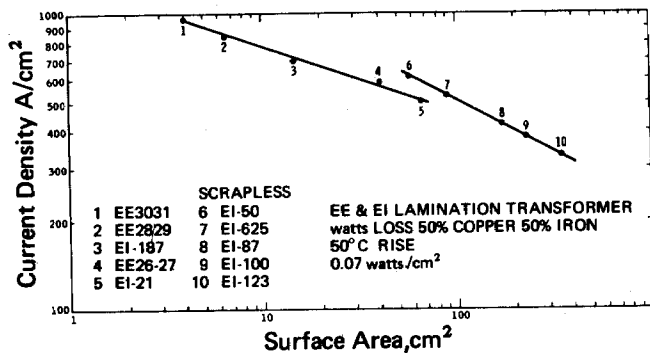

Fig. 53. Current Density vs. Surface Area for a 50° C Rise (Toroids)

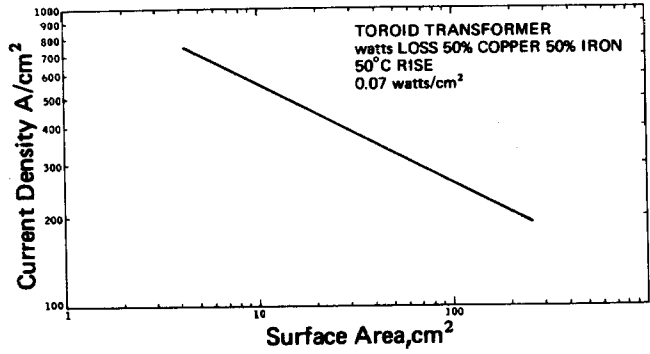

Fig. 54. Current Density vs. Surface Area for a 50° C Rise (C Cores)

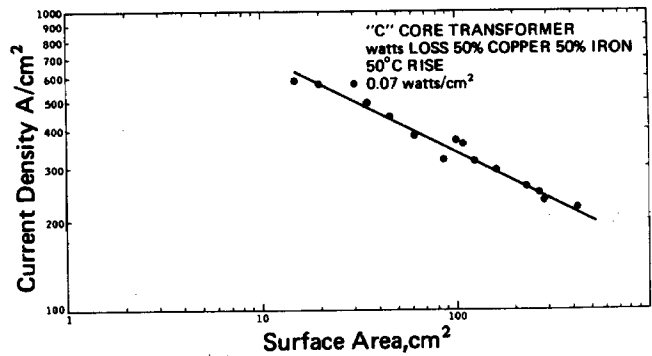

Fig. 55. Lamination A_t

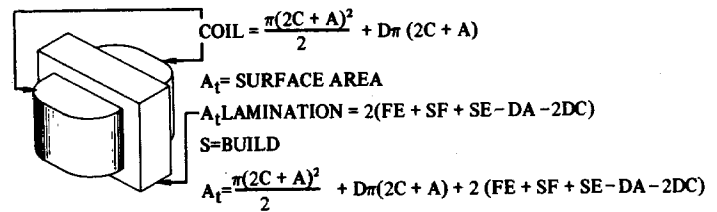

Fig. 56. Toroid A_t

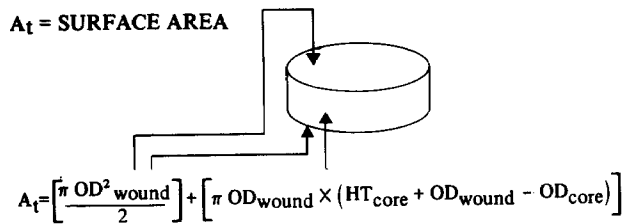
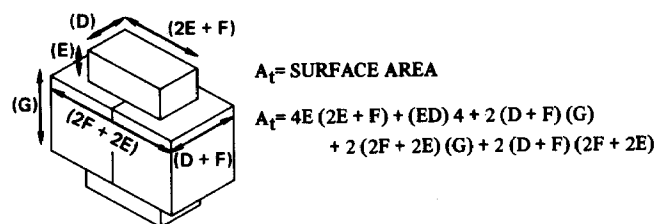

Fig. 57. C Core A_t



14. Permeability and Air Gap

The permeability of a magnetic core is decreased by inserting an air gap. Inserting an air gap causes the magnetization curve to "shear over." The size of air gap can be varied by different stacking methods.

Normal Permeability (μ)* is the slope of a line drawn through the tips of a hysteresis loop formed at a specified value of H or B, as shown in Figure 58. For the maximum flux density B_m , the normal permeability is:

$$\mu = \frac{B_m}{H}$$

*This is not to be confused with $\mu\Delta$ or $\mu\Delta$ per manufacturer's data (Ref. 5).

Fig. 58. Hysteresis Loop

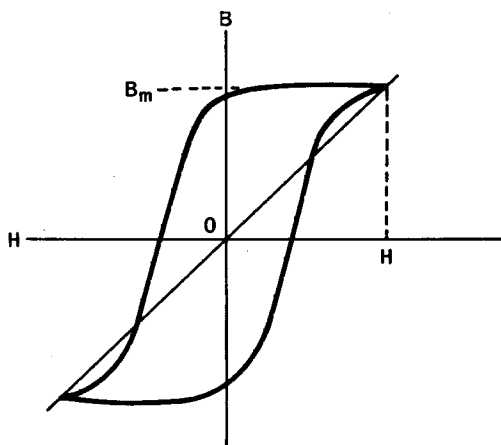

Eight coils were wound to show different stacking methods and their effect on relative air gap.

- Stacking method: 1 X 1
- 5 X 5
- 15 X 15
- 32 X 32
- Butt
- Butt 25 μm Kraft (μm =micrometer)
- Butt 50 μm Kraft
- ½ stack (1 X 1 interleave); ½ Butt stack

Figures 59 through 66 show how the stacking method can influence the permeability. The lamination used and test condition:

Size	E1-375
Material	Permalloy 80
Thickness	0.006
Area	0.91 cm ²
Flux density	0.1 T/cm
ℓ_m	7.3 cm
Turns	70
Frequency	2.4 Kilohertz

Fig. 59.

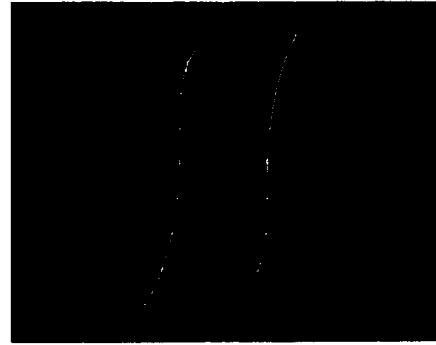

10 ma/cm horiz.
Stack 1 x 1

Fig. 60

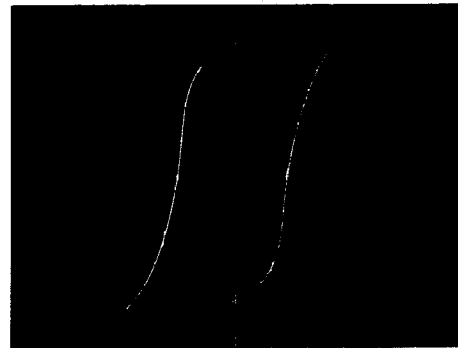

10 ma/cm horiz.
Stack 5 x 5

Fig. 61

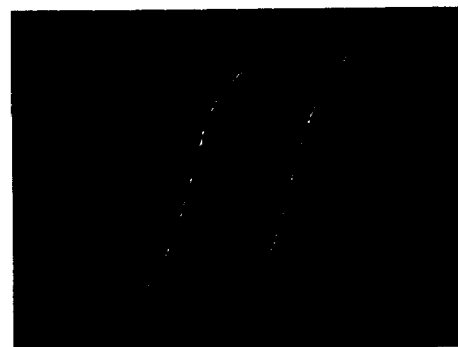

20 ma/cm horiz.
Stack 15 x 15

Fig. 62

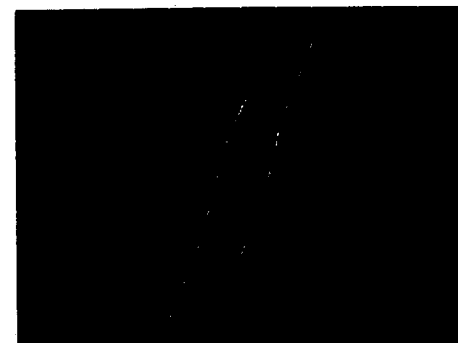

50 ma/cm horiz.
Stack 32 x 32

15. Engineering Aids

Fig. 63

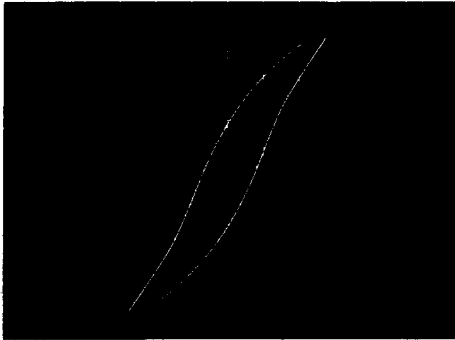

50 ma/cm horiz.
Butt Stack

Figures 67 through 69 and Table 42 have been inserted for use as engineering aids. The nomograph shown in Figure 67 is for Inductance, Capacitance, and Reactance. Figure 68 can be used to compute the mean turn length and its derivation. Figure 69 compares core loss of four different magnetic materials. These curves show core loss as a function of flux density and frequency. Table 42 is a list of the AIEE preferred tape wound toroidal cores, tabulated with metric dimensions.

As an additional engineering aid, common waveshapes are shown below.

Common Waveshapes (RMS Values)

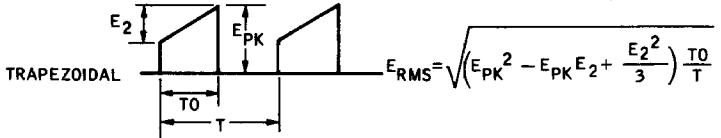
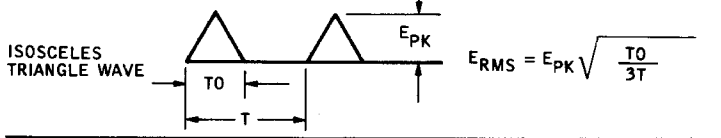
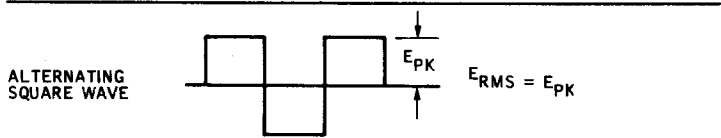
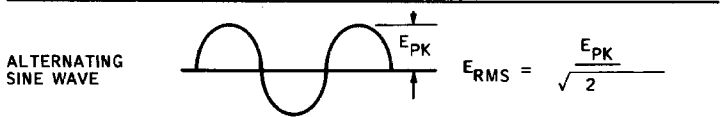
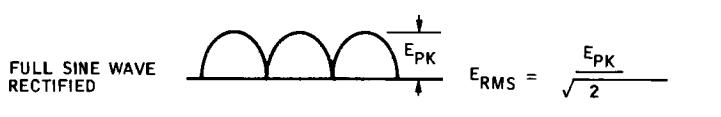
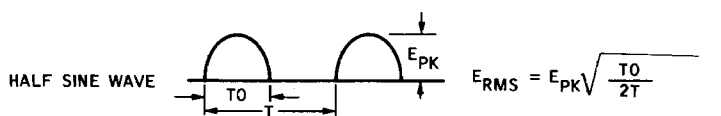
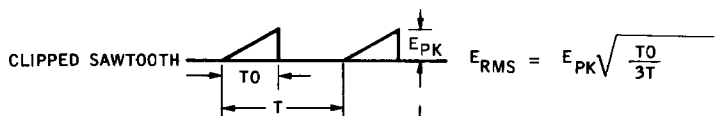
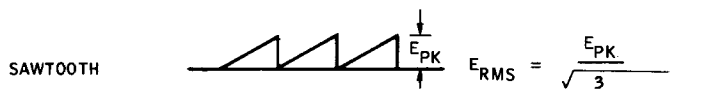
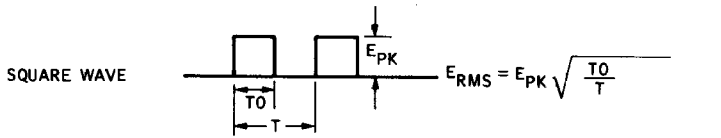
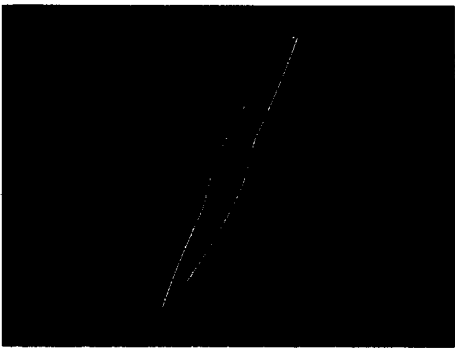
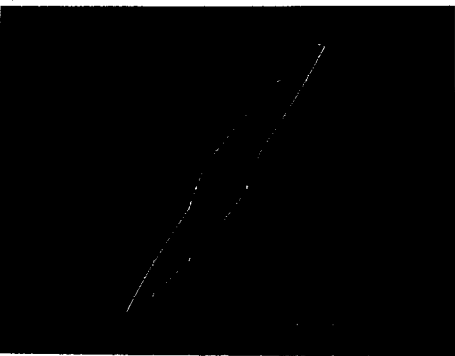

Fig. 64



200 ma/cm horiz.
Butt Stack
25 μ m gap

Fig. 65



200 ma/cm horiz.
Butt Stack
50 μ m gap

Fig. 66

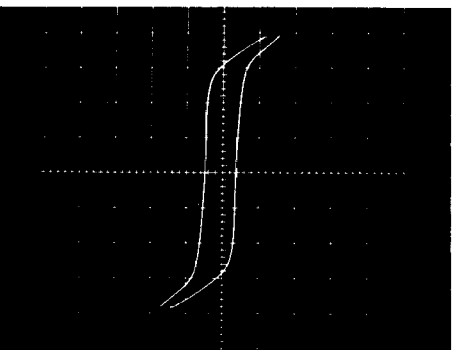

50 ma/cm horiz.
1/2 Stack
(1 x 1 interleave);
1/2 Butt Stack

Fig. 67. Nomograph for Inductance, Capacitance, and Reactance

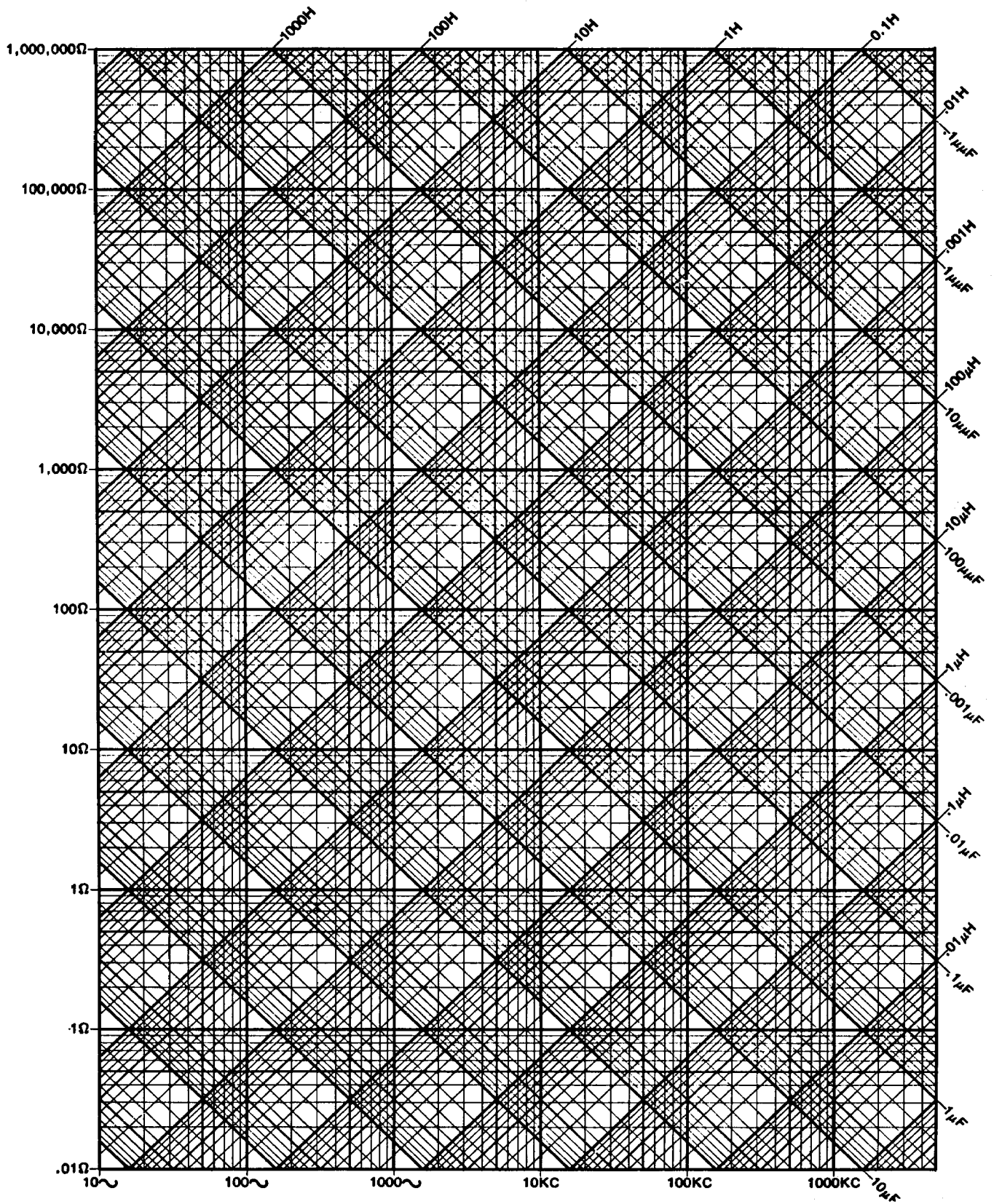
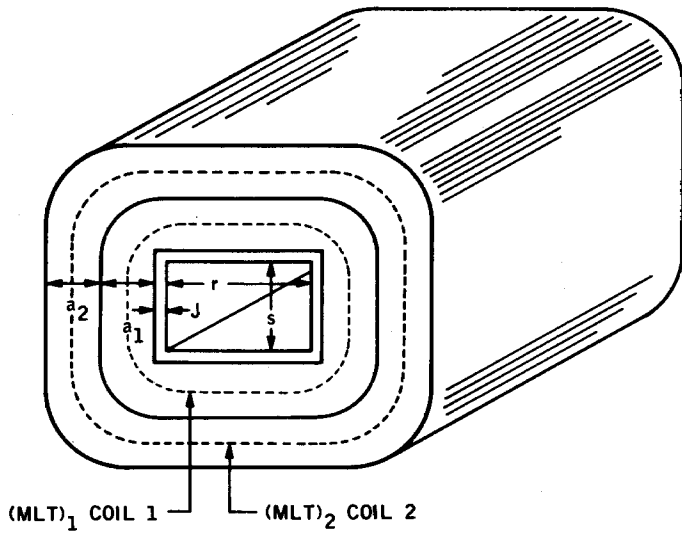

Fig. 68. Computation of Mean Turn Length



$$(MLT)_1 = 2(r+2J) + 2(s+2J) + \pi a_1$$

$$(MLT)_2 = 2(r+2J) + 2(s+2J) + \pi(2a_1+a_2)$$

OR

$$(MLT)_2 = (MLT)_1 + (a_1+a_2+2c)$$

OR

$$(MLT)_n = 2(r+2J) + 2(s+2J) + \pi [2(a_1+a_2+\dots+a_{n-1}) + a_n]$$

WHERE:

a_1 = BUILD OF WINDING #1

a_2 = BUILD OF WINDING #2

a_n = BUILD OF WINDING #n

c = THICKNESS OF INSULATION BETWEEN a_1 & a_2

Fig. 69. Silicon, Cobalt, and Nickel-Iron Core Loss Curves

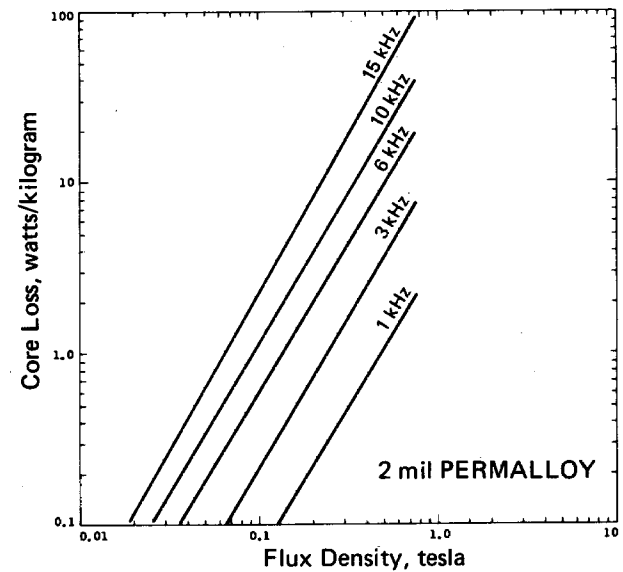
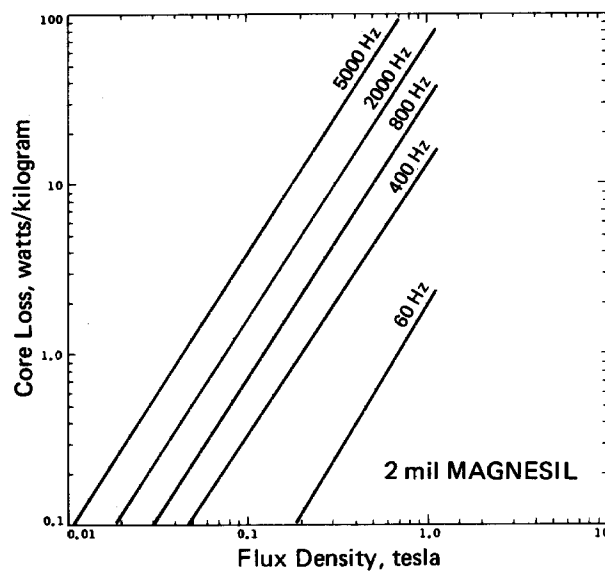
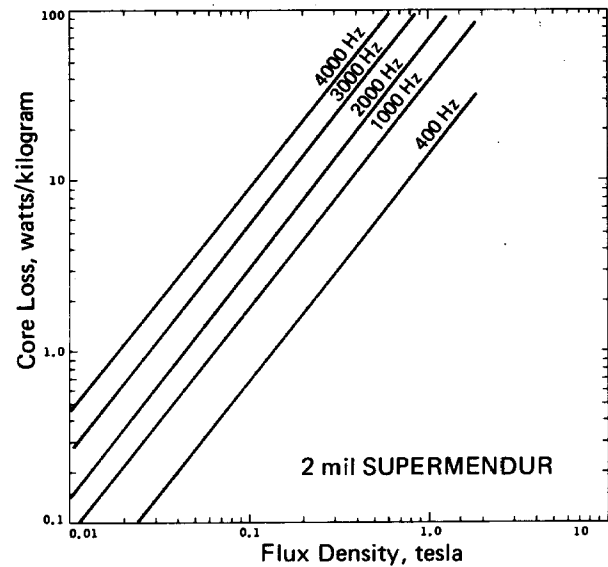
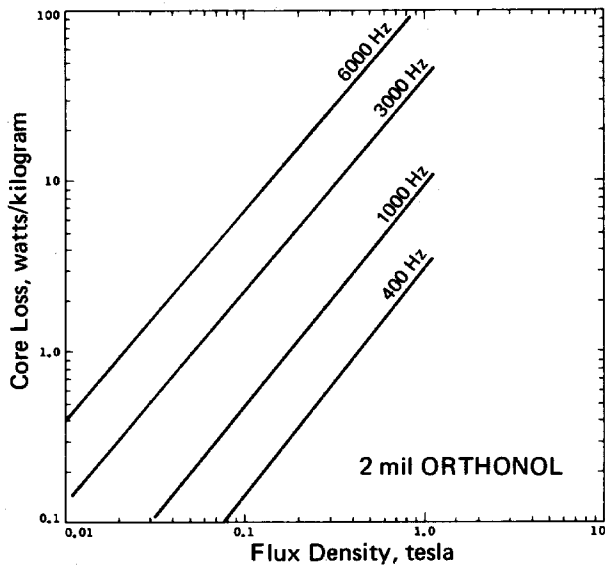

Table 42. A.I.E.E. - Preferred Tape Wound Toroidal Cores

Magnetics	(1) Ac(cm ²)	Wa(cm ²)	(2) ID(cm)	OD(cm)	Height (cm)	ℓ _m (cm)	Core wt (grams)	Ac × Wa(cm ⁴)
52056	0.043	0.877	1.057	1.801	0.643	4.49	1.67	0.0377
52000	0.086	0.794	1.006	2.169	0.643	4.99	3.73	0.0682
52076	0.193	1.38	1.323	2.804	0.803	6.48	10.9	0.266
52007	0.257	1.38	1.323	2.804	0.960	6.19	14.5	0.355
52002	0.086	1.51	1.387	2.550	0.643	6.98	4.62	0.129
52061	0.171	2.11	1.641	2.804	0.960	7.48	10.4	0.361
52106	0.193	2.11	1.641	3.122	0.803	8.98	12.6	0.407
52011	0.086	4.07	2.276	3.439	0.643	8.98	6.71	0.350
52004	0.171	4.07	2.276	3.439	0.960	9.43	13.4	0.696
52029	0.257	4.16	2.301	3.731	0.973	9.97	21.2	1.069
52032	0.343	4.07	2.276	4.074	0.973	9.97	29.8	1.396
52026	0.514	4.07	2.276	4.074	1.290	9.97	44.7	2.092
52038	0.686	4.07	2.276	4.074	1.608	11.96	59.6	2.79
52030	0.343	6.65	2.911	4.709	0.973	11.96	35.8	2.28
52035	0.686	6.65	2.911	4.709	1.608	11.96	65.6	4.56
52425	0.771	6.65	2.911	5.344	1.290	12.96	87.2	5.13
52001	1.371	9.45	3.470	6.690	1.679	15.95	191	12.95
52018	0.257	11.7	3.863	5.344	0.973	14.46	32.4	3.00
52017	0.686	17.6	4.740	6.690	1.679	17.95	107	12.07
52103	1.371	17.6	4.740	7.960	1.679	19.94	238	24.12
52022	2.742	17.6	4.740	7.960	2.949	19.94	477	48.25
52031	0.686	28.4	6.010	7.960	1.679	21.93	131	19.48
52128	1.371	28.4	6.010	9.230	1.679	23.93	286	38.93
52042	2.742	28.4	6.010	9.230	2.949	23.93	572	77.87
52100	5.142	28.4	6.010	9.865	4.219	24.93	1117	146.03
52081	5.142	49.2	7.915	11.770	4.219	30.91	1386	253
52427	7.198	49.2	7.915	13.040	4.219	32.90	2065	354
52112	6.855	75.7	9.820	13.675	5.489	36.89	2205	519
52426	10.968	75.7	9.820	15.580	5.489	39.88	3814	830

(1) Cross-sectional area calculated for 2 mil (0.002 in.) material
 (2) Dimensions listed are sizes of aluminum boxed cores (not coated)

References

1. *Magnetic Wire Datalator*. REA Magnetic Wire Co., Inc., Fort Wayne, Ind., 1958.
2. *Molypermalloy Powder Cores*. Catalog MPP-303S, Magnetics, Butler, Pa.
3. *Design Manual Featuring Tape Wound Cores*. Design Manual TWC-300, Magnetics, Butler, Pa.
4. Blume, L. F., *Transformer Engineering*. John Wiley & Sons, Inc., New York, N. Y., 1938.
5. Lee, R., *Electronic Transformers and Circuits*. Second Edition. John Wiley & Sons, New York, N. Y., 1958.
6. *NY Glass Co.*, 7314 E. Madison St. Paramount, Calif. 90723
Dorco Electronics, 15533 Vermont Ave., Paramount, Calif. 90723
7. *Hallmark Metals*, 610 West Foothill Blvd., Glendora, Calif. 91740.



A Division of Spang Industries Inc.

COMPONENTS DIVISION

Butler, Pa. 16001

Telephone (412) 285-4711 TWX 710-373-3821

WEST COAST DISTRICT SALES OFFICES

S. El Monte, California 91733

Telephone (213) 686-0920 TWX 910-587-3439

San Jose, California 95129

Telephone (408) 253-0591 TWX: 910-338-0046

Tape Wound Cores • Bobbin Cores

Permalloy Powder Cores • Ferrite Cores

Laminations • Photoetched Parts

Custom Components